

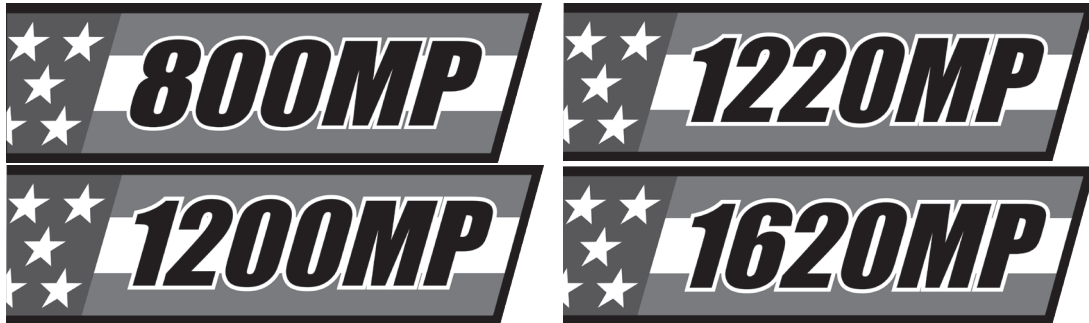

MP SERIES MORTAR/PLASTER MIXERS

Includes Models: 800MP, 1200MP, 1220MP & 1620MP



104 S. 8th Ave. | Marshalltown, IA
Phone 800-888-0127 / 641-753-0127 | Fax 800-477-6341 / 641-753-6341
www.MARSHALLTOWN.com
WS3022

INTRODUCTION

Congratulations on your purchase of a MARSHALLTOWN MP Series Mortar/Plaster Mixer. Made in the USA, MARSHALLTOWN mixers are rugged and heavy-duty, ready for years of service. MARSHALLTOWN mixers have several options to suit every contractor's needs. Among those are:

- 8, 12, and 16 cubic foot drums
- Mechanical or hydraulic drive
- Manual or hydraulic dump
- 2" (51mm) ball or pintle hitch
- Honda® gasoline engines, or multiple electric motor options

The paddle design of your MARSHALLTOWN mixer has several advantages. Our paddles are bolted into place, allowing for easy replacement. They also have separate drum scrapers which continually clean the side of the drum and help move material to the middle of the drum. Our 4/2, 2/2, and 6/2 paddle design ensure "Batch a Minute" results.

Other features of your MARSHALLTOWN mixer include:

- Heavy gauge steel on the entire unit
- Solid axles on all mixers
- Double belt drive on mechanical mixers
- Square paddle shaft for reduced slippage and better efficiency
- Structural steel frame
- High-speed tow kit with 25" (635mm) tires

This owner's manual provides the information needed to operate and maintain this MARSHALLTOWN Mixer. Carefully read and follow all safety and operating instructions in this manual. Ensure every operator of this mixer reads this manual before operating the mixer. The replacement of any part on this mixer by other than the manufacturer's authorized replacement part may adversely affect the performance, durability or safety of the product.

Be sure safety precautions are observed. Read and follow all safety and operating instructions in this operator's manual. The manufacturer reserves the right to make changes on or add improvements to its product at any time without prior notice or obligation. The manufacturer reserves the right to decide, upon its sole discretion and at any time, to discontinue a product.

Information regarding operation and maintenance of the engine can be found in a separate engine manual supplied with this mixer, if the mixer is supplied with an engine. The engine manual provides all the information required regarding engine adjustments, operation and maintenance. Should any questions arise concerning engine operation or service, contact the nearest engine repair facility or the engine manufacturer.

This manual covers all MARSHALLTOWN MP Series Mortar/Plaster mixer models and options. For technical questions or repair parts, please call MARSHALLTOWN customer service at 800-888-0127, 641-753-6341 or visit www.MARSHALLTOWN.com

TABLE OF CONTENTS

Safety Precautions	3-4
Safety Decals	5
Warranty	6
Specifications	7-9
Assembly	9
Product Operation	10-13
Parts Breakdown	14-40
Maintenance.....	41
Troubleshooting.....	42



SAFETY PRECAUTIONS

UNDERSTAND SIGNAL WORDS

- A signal word - DANGER, WARNING, or CAUTION is used with the safety-alert symbol. DANGER identifies the most serious hazards.



- DANGER or WARNING safety signs are located near specific hazards.



- General precautions are listed on CAUTION safety signs.

- This notation appears before warnings in the text. It means that the step that follows must be carried out to avoid the possibility of personal injury or death. These warnings are intended to help the technician avoid any potential hazards encountered in the normal service procedures. We strongly recommend that the reader takes advantage of the information provided to prevent personal injury or injury to others.

THE FOLLOWING PRECAUTIONS ARE SUGGESTED TO HELP PREVENT ACCIDENTS. A CAREFUL OPERATOR IS THE BEST OPERATOR. MOST ACCIDENTS CAN BE AVOIDED BY OBSERVING CERTAIN PRECAUTIONS. READ AND TAKE THE FOLLOWING PRECAUTIONS BEFORE OPERATING THIS EQUIPMENT TO HELP PREVENT ACCIDENTS. EQUIPMENT SHOULD BE OPERATED ONLY BY THOSE WHO ARE RESPONSIBLE AND INSTRUCTED TO DO SO.



- CALIFORNIA PROPOSITION 65 WARNING: Operation of this equipment and/or engine exhaust from this product contains chemicals known to the State of California to cause cancer, birth defects, or other reproductive harm.

- Read all operating and maintenance instructions before operating or servicing mixer. Test run empty prior to actual use.
- A mixer is only as safe as its operator. Give complete and undivided attention to the operation of the mixer.
- Know how to stop the mixer and the engine instantly.
- Always have all guards and safety devices attached and in place before operating mixer. Close engine housing during operation.
- Keep inexperienced and unauthorized people away from the mixer at all times.
- Never leave the mixer unattended while it is running.
- Shut off engine or disconnect the electric motor before making any adjustments or putting hands or tools in the drum.

SAFETY PRECAUTIONS CONTINUED



Never reach into the drum or place tools into the drum while the mixer is running.

- Do not overfill the drum. Do not exceed the mixer's rated capacity.
- Do not smoke while refueling the engine. Shut off the engine and allow it to cool before refueling. Do not spill fuel.
- Block mixer wheels when mixing.
- Use safety chains while towing mixer.
- Keep the mixer in good operating condition. Loose or damaged parts are dangerous.
- Avoid loose clothing that could get caught in moving parts or on control levers.



Keep hands and feet away from moving parts.

- Do not add material to the drum while stopped. Start the drum before adding material.
- Keep all warning, caution and safety instruction labels in good condition. Replace missing, damaged or illegible labels.
- Clear the work area around the machine to prevent tripping or falling onto the mixer.
- Operate on level ground to prevent the mixer from tipping over.
- DO NOT OPERATE this mixer under the influence of alcohol or while taking medication that impairs your reactions.
- Do not pull the cord to disconnect it. Keep the cord away from heat, oil, and sharp edges.
- Use factory authorized parts for replacement.
- Wear safety glasses when mixer is in use.
- Never attempt to move the mixer while the motor is on.
- With electric motors, properly grounded electric circuit is required to protect the operator from possible electric shock.



NEVER unplug the motor while standing in or around wet ground.

TOWING & SAFETY CHAINS

For transporting the mixer, slide the tow pole out as far as possible and insert the locking pin. When operating the mixer, slide the tow pole in and lock it in place. Make sure drum is locked in position and engine housing is closed and secured.

Cross the safety chains under the tow pole and fasten them to the tow vehicle. (See figure 1.)

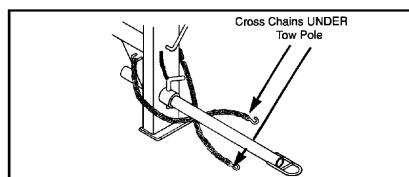

Figure 1

NOTE! Safety chain length may need to be altered for proper connection to tow vehicle. Reposition the hooks, DO NOT cut chain. Allow enough slack to permit proper vehicle turning while keeping chains snug enough to prevent tow pole from contacting the ground in case the hitch uncouples.

SAFETY DECALS

If your safety and operating decals are damaged, they can be replaced by contacting Customer Service.

WS1195

SAFETY AND OPERATING INSTRUCTIONS

CAUTION!

1. Never reach into drum while mixer is running.
2. Stop engine or motor before cleaning or servicing.
3. Keep children and unauthorized people away from machine.
4. Never allow machine to run unattended.
5. Read owner's manual before operating or servicing this machine.

CLEANING

1. With paddles rotating, add water.
2. Allow paddles to turn for several minutes.
3. Dump water and spray remaining mortar with hose.
4. Stop mixer by switching motor off or stopping engine.
5. Thoroughly clean with water before any remaining mortar hardens.

LUBRICATION & SERVICE

1. Lubricate the following daily prior to use:
 - Drive shaft bearings
 - Drum shaft bearings and seals
 - Chain and sprockets
2. Service engine or motor per manual supplied.

WS1195

WS1065

! WARNING



Do Not Operate With Cover Open

WS1065

WS1198

MIX NEUTRAL

WS1198

WS1070

! WARNING



Shut Off Motor/Engine to Service or Clean

WS1070

MIXERS ONE-YEAR WARRANTY

This product is warranted to the original purchaser only, to be free of defects in material and workmanship under normal use, for one year from purchase date. Marshalltown Company shall without charge for parts and labor, repair or replace such parts which are found to be defective. All transportation charges for replacement parts must be borne by the purchaser.

For warranty service, the product must be delivered, with proof of purchase date, to the dealer of original purchase, or any factory authorized service dealer.

If difficulty is encountered in having warranty work performed, contact the factory Service Department.

All implied warranties, including those of merchantability and fitness for a particular purpose, are limited to one year from date of purchase by the original retail customer and to the extent permitted by law any and all implied warranties are excluded and disclaimed after the expiration of such period.

Some states do not allow limitations on how long an implied warranty lasts, or the exclusion or limitations of incidental or consequential damages, so the above limitations or exclusions may not apply to you. This warranty gives you specific legal rights, and you may also have other rights, which vary from state to state.

Exclusion from this warranty:

1. The following items are not covered under the Marshalltown Company one year warranty and are warranted by their respective manufacturer.
 - a) Engines, including starters, generators, alternators and gear reducers
 - b) Hydraulic components, including pumps, motors and valves
2. All consequential damages, including pickup and delivery of the unit, communication, mileage charges and/or rental of a replacement unit during repairs are not covered under this warranty, nor are any loss of income and/or other loss resulting from the failure of the product to function due to a warranty defect.
3. This warranty will not apply when the product becomes inoperative due to misuse, normal wear, neglect, improper maintenance, accident or freight damage; has not been operated and maintained in accordance with the instructions furnished in the Operator's Manual; or has been altered or modified without approval from the factory Service Department.
4. No parts or products are to be returned to the factory without prior written approval from the factory.

SPECIFICATIONS

800MP

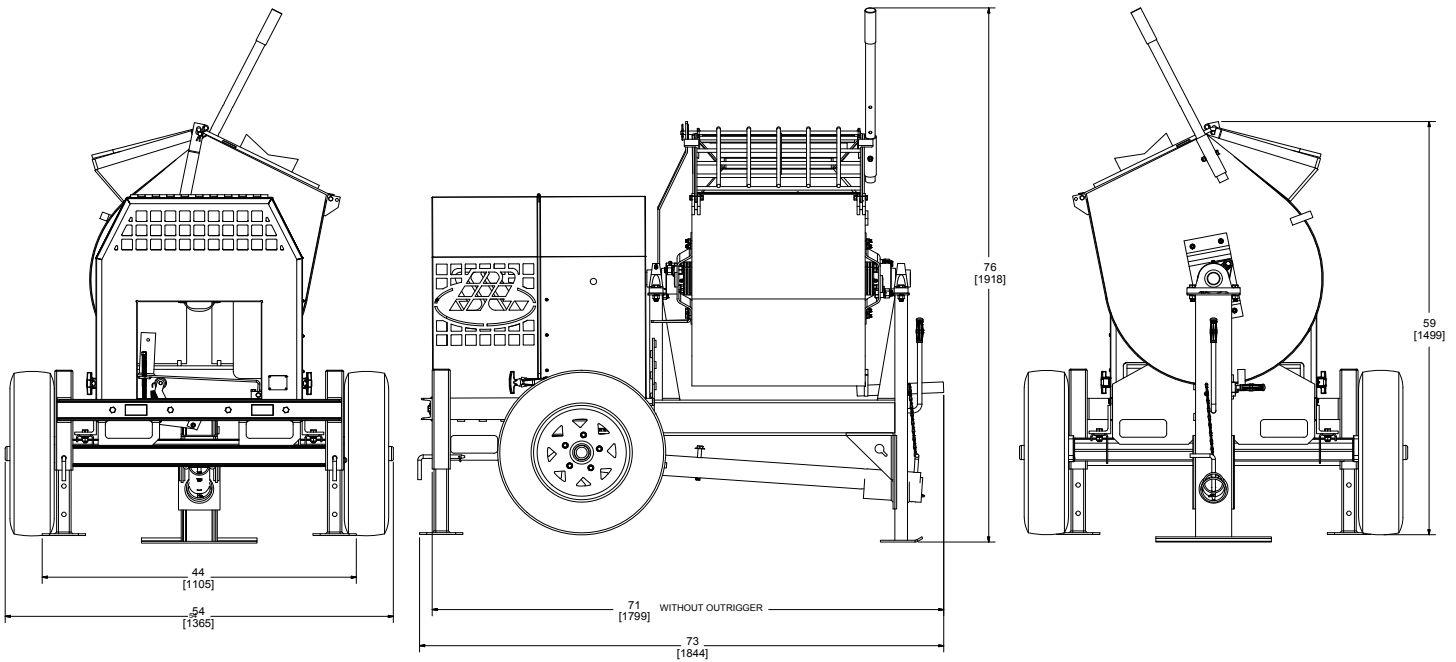

1200MP

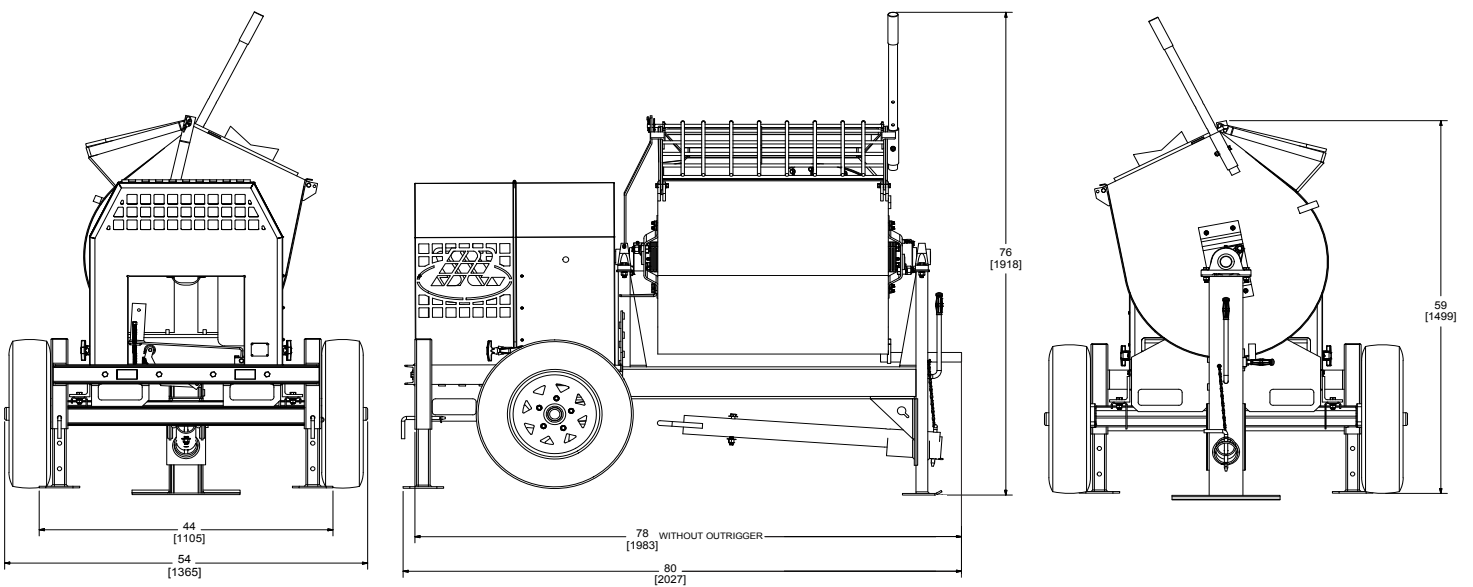

SPECIFICATIONS

1220MP

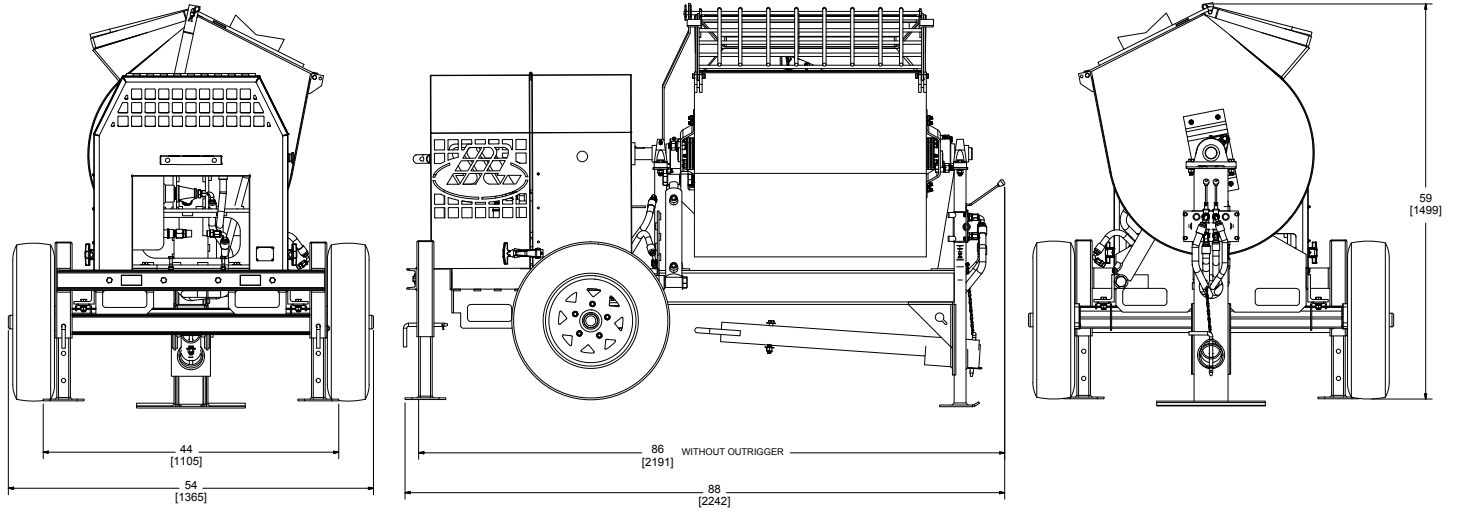

1620MP

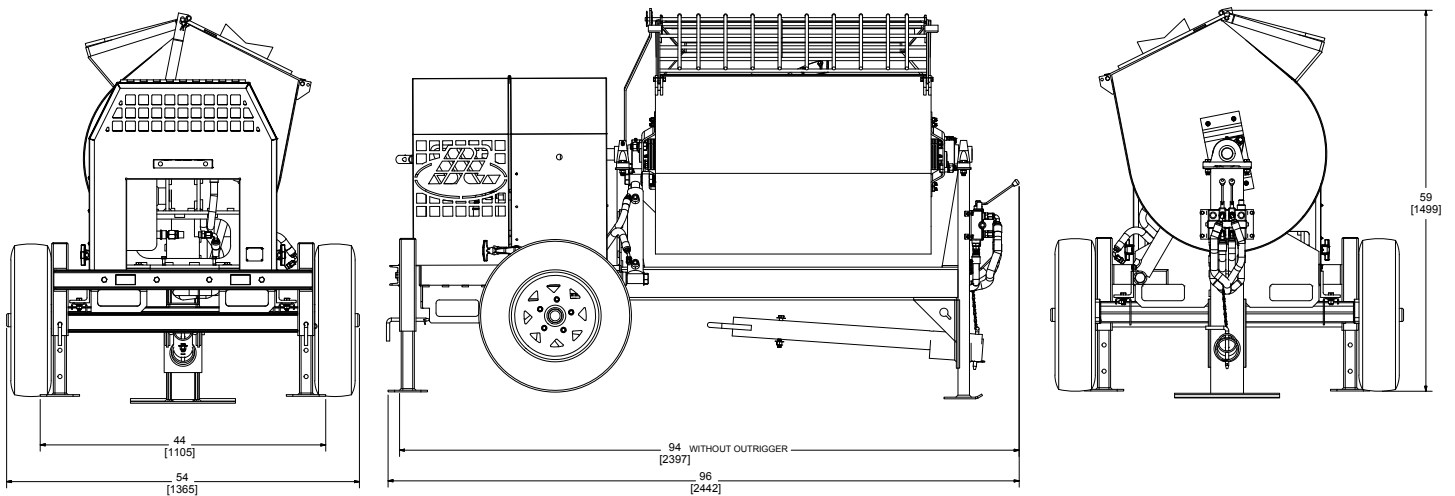

SPECIFICATIONS

Model	Batch Volume Cu. Ft.	Total Drum Volume Cu. Ft.	Batch Cap. Bags	Bearing/Seal	Clutch Mechanism	Power Reduction
800MP	8	9.8	2	Roller Bearings w/Stacked Seals	Pivoting Engine Mount	6:1 Reduction; Belt to Chain & Sprocket
1200MP	12	14.1	4	Roller Bearings w/Stacked Seals	Pivoting Engine Mount	6:1 Reduction; Belt to Chain & Sprocket
1220MP	12	14.1	4	Roller Bearings w/Stacked Seals	Hydraulic	Hydraulic
1620MP	16	17.4	5	Roller Bearings w/Stacked Seals	Hydraulic	Hydraulic

Model	Tow Pole	Wheel & Tire	Overall Dimensions L X W X H	Discharge Height	Power Options
800MP	2-7/8" Dia. Telescoping	6.5" X 13" Wheels 25" O.D. Tires	73" X 54" X 59"	24"	3HP Electric 8HP Honda®
1200MP	2-7/8" Dia. Telescoping	6.5" X 13" Wheels 25" O.D. Tires	80" X 54" X 59"	24"	3HP Electric 8HP Honda®
1220MP	2-7/8" Dia. Telescoping	6.5" X 13" Wheels 25" O.D. Tires	88" X 54" X 59"	24"	7.5HP Electric 13HP Honda®
1620MP	2-7/8" Dia. Telescoping	6.5" X 13" Wheels 25" O.D. Tires	96" X 54" X 59"	24"	7.5HP Electric 13HP Honda®

ASSEMBLY

TOW POLE

The tow pole assembly is located on the front of the mixer and is used for transport only. For transport, pull the tow pole assembly out, line up the holes and insert the L-shaped pin through each hole. While operating the mixer, pull the L-shaped pin out of the hole and push tow pole assembly all the way in. Line up the holes and insert the L-shaped pin through each hole.

ELECTRIC MOTORS

Electric Motors on MP mixers are sold WITHOUT a power cord because of the variety of voltage/plug configurations available. Most electrical supply stores can provide the correct wiring harness and plug for any application.

HYDRAULIC PUMPS

No hydraulic assembly required. The speed of the mixing shaft can be adjusted using the flow control inside the engine house. Hydraulic mixers use AW 32 hydraulic fluid.

GREASING

All mixers are greased before their factory test, but each unit should be greased prior to its first use (see lubrication section on page 12). This will replace any grease that was lost or contaminated during transport.

DRUM WIPER BLADES

The mixing paddles feature adjustable rubber wipers and steel backing plates. Wipers are factory preset to lightly contact the inside of the drum.

MIXER TRANSPORT

Secure drum by engaging drum lock. Secure all moveable parts, including the rear housing. Secure tow pole coupler to vehicle and attach safety chains and hooks. (See Figure 1, Safety Chains). The included pintle-type couplers require the appropriate tow vehicle coupler retainer.

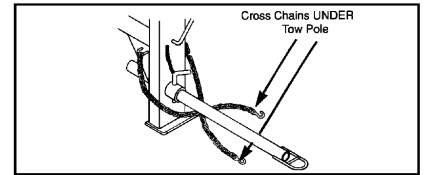

Figure 1

PRE-OPERATIONAL CHECKS

The following steps should be taken prior to placing the mixer in use:

1. The operator must be familiar with the location and operation of all controls.
2. The unit ships with oil, but check the crankcase oil level on gasoline powered units, and fill the fuel tank before starting.
3. Check for free rotation of the mixer blade shaft by rotating the drum through one complete dump-charge-dump cycle.



Make sure no foreign objects or tools are in drum before starting engine/motor.

4. When turning the unit on for the first time, make sure the paddles are turning the right direction. If the paddle direction is incorrect, consult the motor wiring diagram (can be found inside the wiring enclosure or on the nameplate of the motor) to reverse the direction.
5. Start engine/motor, slowly engage the drum drive and check for smooth operation of the mixer blade shaft and drive.
6. Verify that all power cords are running in a safe direction and clear of all gears, belts, or other moving parts.
7. Move the clutch lever through several cycles to assure correct clutch operation.
8. Use the dipstick to check the hydraulic fluid level in the reservoir.
9. Make sure the drum latch is disengaged prior to extending the dump cylinder.

CONTROLS AND OPERATIONS



Read through the manual for all operation, adjustment and maintenance instructions. Be sure all engine/motor and drive system operation instructions are followed as outlined.

All nuts and cap screws should be checked and tightened during the first two (2) hours of use. Periodic checks should be made thereafter.

WIPER BLADE ADJUSTMENT



Ensure mixer is unplugged (electric) or spark plug removed (gasoline) to prevent accidental starting.

The mixing paddles feature adjustable rubber wipers and steel backing plates. Wipers are factory preset to lightly contact the inside of the drum.

If adjustment is required, proceed as follows:

- A. Loosen the wiper attaching hardware and move the wiper outward to maintain contact with the drum but without folding over when in operation.
- B. After adjustment, turn the mixer arms one full turn manually to check clearance and eliminate the possibility of wiper back plates contacting the drum.

CLUTCH CONTROL LEVER



To avoid personal injury, this control must be disengaged before starting engine/motor or when mixer is not in use.

This control is located in front of the mixing drum on the mixer leg. (See Figure 2.)

This control engages and disengages the drive to the mixing blades.

TO ENGAGE: Position lever in line with the mixer frame (12 o'clock position). Lever is held in the engage position by the over-center action of the linkage.

TO DISENGAGE: Push lever down (counter-clock-wise) to the 9 o'clock position. Lever is spring loaded to hold it in the disengaged position.

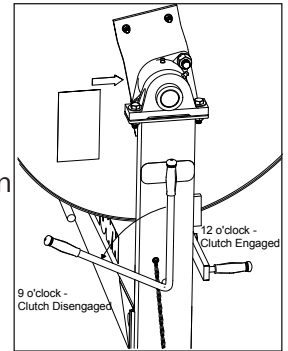

Figure 2

STARTING THE MIXER



To avoid personal injury, be sure control lever is in the neutral position before starting engine/motor

Start the mixer engine/motor. Refer to the engine/motor manual for proper starting procedures.

When the engine/motor is warmed up and is running smoothly, move the control lever to engage the clutch.

Ram dump mixers have 3 paddle settings: Forward, Neutral, Reverse (See Figure 2.1)

Ram dump mixers have 3 drum settings: Tilt Forward, Load/Mix, Tilt Backward (See Figure 2.1)

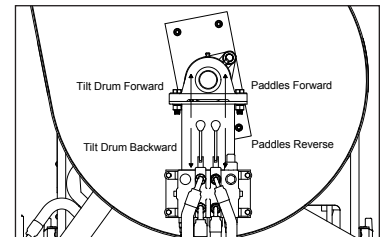

Figure 2.1

EXTENSION CORDS FOR ELECTRIC MOTORS

Follow your local or state standards, or the National Electric Code, to determine the correct gauge of wire when using an extension cord with your electric motor.

LOADING THE MIXER



To avoid personal injury, be sure grill assembly is down and in place when mixer is in operation



To avoid personal injury, be sure drum is locked in the operating position

When the mixing blades are rotating, pour the required amount of water into the drum, then add cement, sand and lime or mortar mix. The desired mixing speed is 33 RPM.

DISCHARGING THE MIXER



Keep hands and all foreign objects clear of the moving paddles while discharging the mixer.

MANUAL DUMP

1. Allow the entire mixture to mix for one (1) full minute.
2. DO NOT STOP MIXER FROM ROTATING.
3. Hold the tilt handle and disengage the drum lock.
4. Dump motor to the side by pulling the tilt lever downward.
5. After the mixture is dumped, return the drum to the operating position and engage drum lock.

RAM DUMP

1. Slowly push forward on the left-hand control lever on the control valve. The farther the valve is pushed, the faster the drum will tilt.
2. With the drum in the discharge position, use the right-hand control lever to engage the paddles and discharge the mix.
3. Pull the left-hand control lever toward you to return the drum to the load/mix position.

LUBRICATION



To avoid personal injury, always turn off engine/motor and wait for all motion to stop before making adjustments or repairs.

DRUM SEAL PLATE ASSEMBLIES

Drum seals are provided on each end of the drum where the mixing shaft passes through to the bearings. It is important to pump grease into the assemblies to retain seal efficiency. Use enough grease to flush out old grease and carry away any grit. Use lithium based grade 2 multi-purpose grease. See Figure 3.1

MIXING SHAFT BEARINGS

The mixing shaft bearings are permanently factory sealed and lubricated, and should not require further service.

WHEEL BEARINGS

Wheel bearings should be packed once a year. Thoroughly clean old lubricant from the bearings, hub and spindles before repacking. Pack bearings only one-half to two-thirds full with grease to prevent overheating. Use no. 2 wheel bearing grease.

DRUM SHAFT BEARING HANGERS

Drum yoke bearing hangers are located on each side of the drum, and are equipped with grease fittings. These bearings should be lubricated once each week with lithium based grade 2 multi-purpose grease.

See Figure 3.1

ENGINE/MOTOR

Refer to the engine/motor operating instructions for all maintenance and lubrication instructions and requirements.

DRIVE SHAFT BEARINGS

Pillow block style bearing are used on the drive shaft. See Drum Seal Plate Assemblies, Lubrication Guidelines for more information. See Figure 3.2

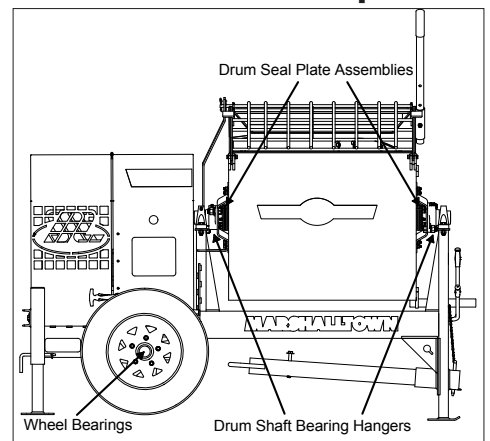

Figure 3.1

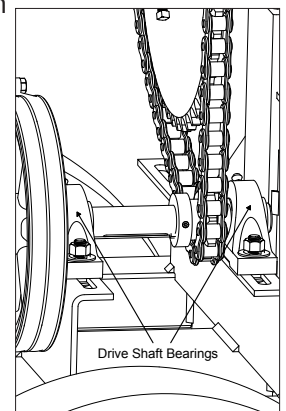

Figure 3.2

CLEANING THE MIXER



To avoid personal injury, always turn engine/motor off and wait for all motion to stop before cleaning.

To achieve satisfactory performance from the mixer, it is essential to give the drum reasonable care. Clean the mixer after each use, before the mortar dries and becomes hard. Never permit mortar to harden on either the inside or outside of the drum. Do not pound or dent the drum as this impairs mixing efficiency and can cause spot wear on the drum surface. Spray the entire unit off after each use.

It is important to keep the inside of the mixing drum free of hardened mortar. After discharging the last batch of mortar each day, add a pailful of water and two shovelfuls of gravel to the drum. This will scour the inside of the drum. Mix for about two minutes, discharge and rinse the drum with water.

ADJUSTMENT



To avoid personal injury, always turn off engine/motor and wait for all motion to stop before making adjustments or repairs.

RUBBER WIPER BLADES

Adjust rubber wipers so they fit snugly against the drum but not to the point that they fold over when the blades rotate.

ENGINE/MOTOR DRIVE

See Figure 4 (800MP & 1200MP Models)

1. Check the roller chain regularly so with one strand tight, the slack strand can be moved approximately one half of an inch. If an adjustment is required, loosen the bolts on the pillow block bearings and slide the pillow block/shaft assembly toward or away from the driven sprocket as necessary.
2. Align the pulleys so the belts will run straight. Make sure all set screws are tightened on the pulleys when you are finished.
3. To set the belt tension, loosen the bolts that hold the engine or motor to the mounting plate. Move the clutch lever to the engaged position. Slide the engine or motor in the mounting slots until the belt is tight, then slide the engine or motor back approximately $\frac{1}{4}$ ". Tighten the mounting bolts.
4. Adjust belt fingers so they allow disengagement of the drive, but they must not touch the belt when the clutch is disengaged.

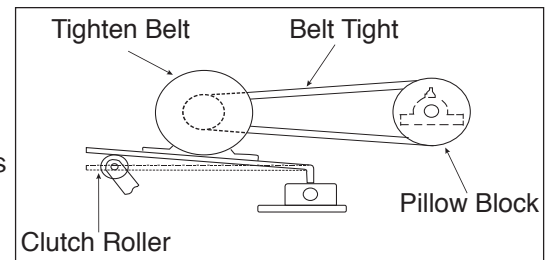

Figure 4

STORAGE

For short term storage, clean the mixer and store in a dry place. If the mixer is not to be used for an extended period of time, service the mixer completely and store in a dry place.

1. Refer to the engine/motor instructions for storage instructions.
2. Cover exposed metal surfaces with a thin coat of SAE 30 weight engine oil.
3. Lubricate per instructions outlined in the LUBRICATION section (page 12).

SERVICING THE MIXER

1. Clean mixer thoroughly.
2. Check all bearings and seals for proper operation.
3. Check mixing arms, blades, and wipers for damage or wear.
4. Any damaged or excessively-worn parts should be replaced.

PARTS BREAKDOWN

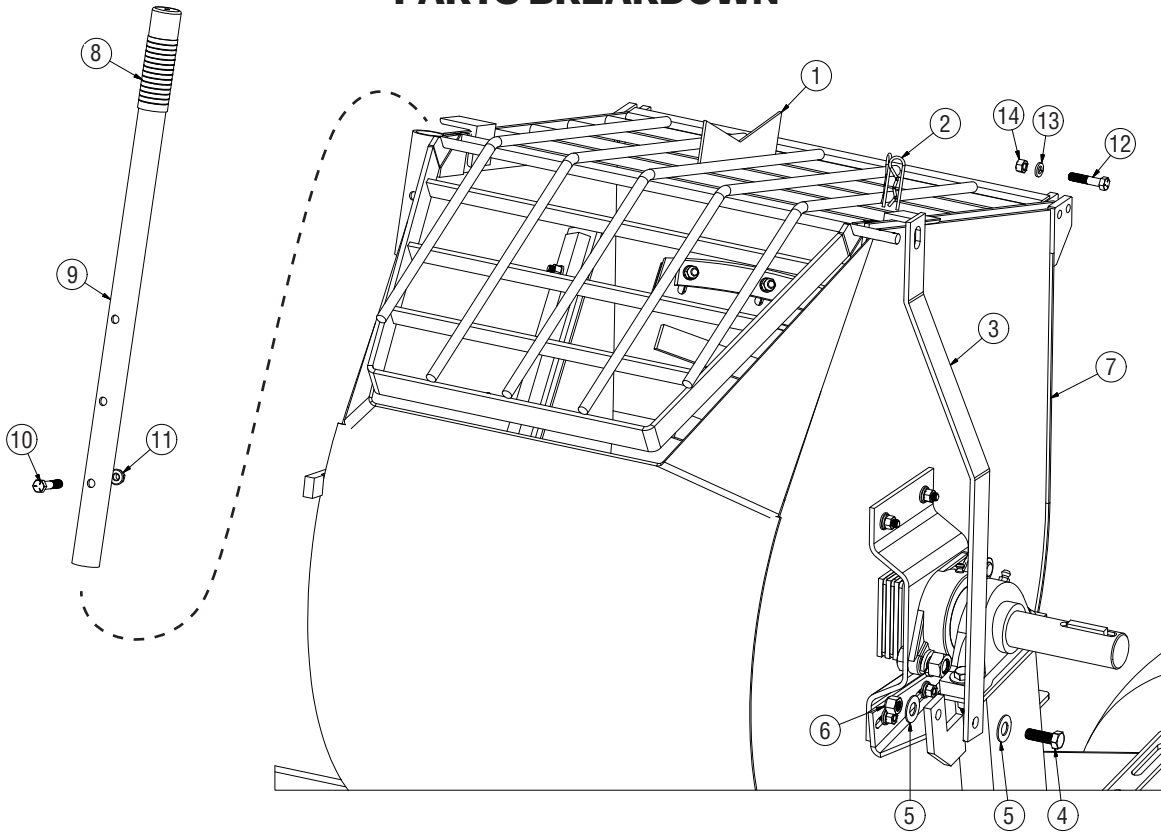

800MP GRILL KIT EDI# 27854 INCLUDES:

REF #	DESCRIPTION	QTY
1	800MP GRILL WELDMENT	1
2	SPRING CLIP FOR LOCKING PIN	2
3	GRILL SAFETY LATCH, MP MIXER	1
4	HEX CAP SCREW, 1/2"-13 X 1 1/2"	1
5	FLAT WASHER, 1/2"	2
6	LOCKING NYLON NUT, 1/2"-13	1

GRILL HINGE HDW KIT EDI #27857 INCLUDES:

REF #	DESCRIPTION	QTY
12	HEX CAP SCREW, 3/8"-16 X 1 1/2"	2
13	LOCK WASHER, 3/8"	2
14	HEX NUT, 3/8"-16	2

800MP DRUM ONLY EDI# 27378 INCLUDES:

REF #	DESCRIPTION	QTY
7	800MP DRUM SHELL	1

DRUM TIP HANDLE W/HDW KIT #27852 INCLUDES:

REF #	DESCRIPTION	QTY
8	HAND GRIP	1
9	TILT HANDLE	1
10	HEX CAP SCREW, 3/8"-16 X 2 1/4"	1
11	HEX NUT, 3/8"-16	1

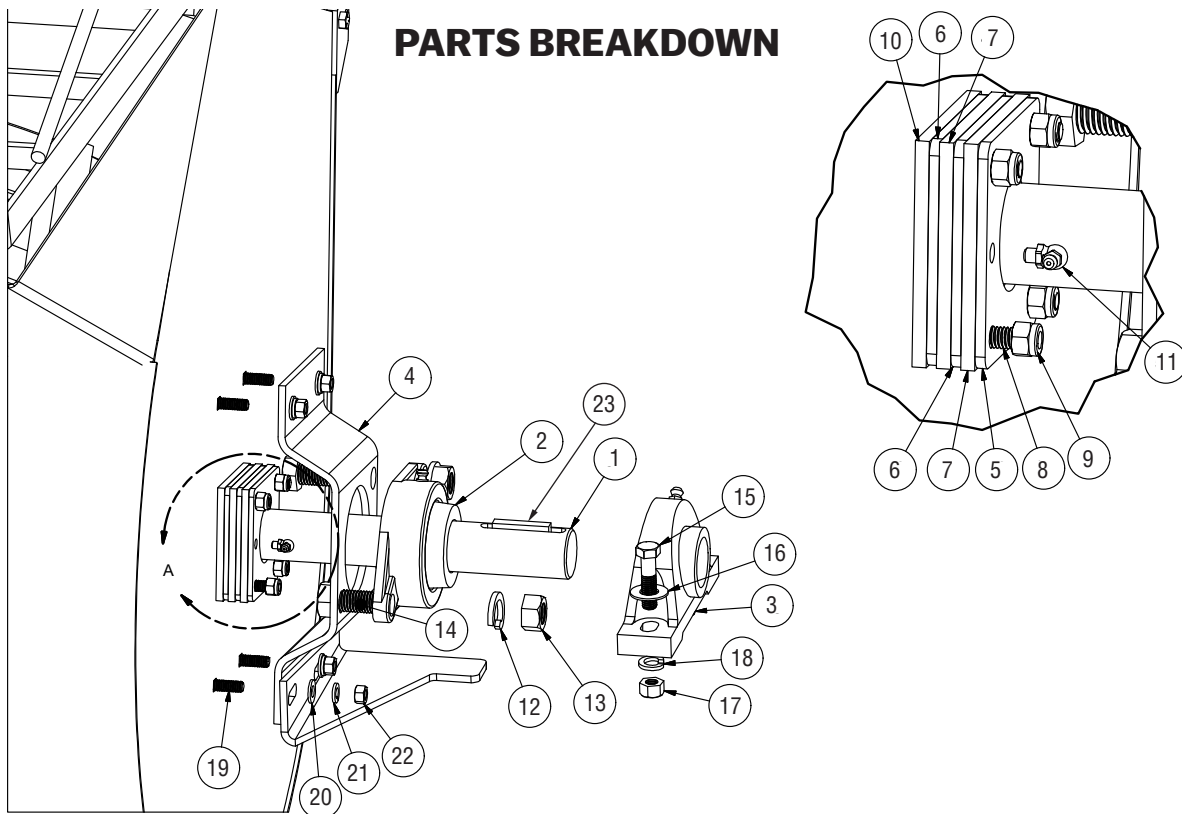

DRUM SHAFT FOR 800MP PARTS BREAKDOWN

REF #	DESCRIPTION	PART#	QTY
1	800MP DRUM SHAFT WELDMENT	MIX27883	1
2	FLANGE MOUNT BEARING, 1-3/4" ID	MIX27860	2
3	PILLOW BLOCK BEARING, 1-3/4" ID	MIX27853	2
4	BEARING SUPPORT BRACKET, MP MIXER	MIX27902	2
5	OUTER SEAL PLATE, MP MIXER	MIX27900	2
6	INNER SEAL PLATE, MP MIXER	MIX27901	4
7	DRUM SEAL, MP MIXER	MIX27904	4
8	CARRIAGE BOLT, 3/8"-16 X 2"	*	8
9	LOCKING NYLON NUT, 3/8"-16	*	8
10	INNER DRUM SEAL, MP MIXER	WX2158	2
11	GREASE ZERK, 1/8" NPT, 90 DEG.	*	2
12	LOCK WASHER, 3/4"	*	4
13	HEX NUT, 3/4"-10	*	4
14	HEX CAP SCREW, 3/4"-10 X 1 3/4"	*	4
15	HEX CAP SCREW, 1/2"-13 X 2"	*	4
16	FLAT WASHER, 1/2"	MIX70707	4
17	HEX NUT, 1/2"-13	MIX70563	4
18	LOCK WASHER, 1/2"	MIX70655	4
19	CARRIAGE BOLT, 3/8"-16 X 1 1/4"	MIX70906	8
20	FLAT WASHER, 3/8"	MIX70703	8
21	LOCK WASHER, 3/8"	MIX70649	8
22	HEX NUT, 3/8"-16	MIX70553	8
23	KEY STOCK, 3/8" SQ X 2	MIX71022	1

*COMMON HARDWARE CAN BE PURCHASED LOCALLY

PARTS BREAKDOWN

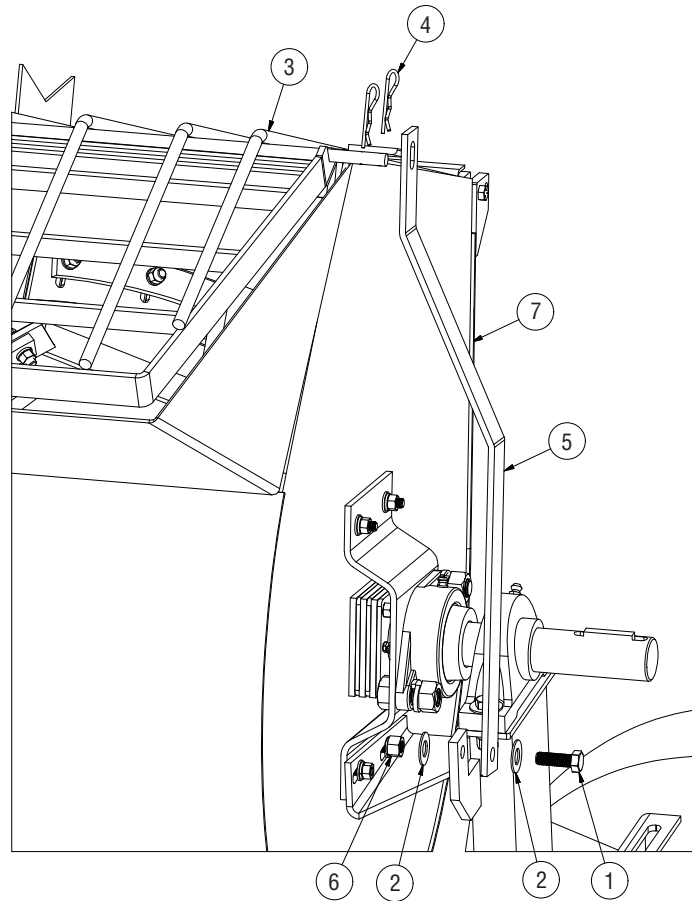

1200/1220MP GRILL KIT EDI# 27855 INCLUDES:

REF #	DESCRIPTION	QTY
1	HEX CAP SCREW, 1/2"-13 X 2"	1
2	FLAT WASHER, 1/2"	2
3	1200/1220MP GRILL WELDMENT	1
4	SPRING CLIP FOR LOCKING PIN	2
5	GRILL SAFETY LATCH, MP MIXER	1
6	LOCKING NYLON NUT, 1/2"-13	1

GRILL HINGE HDW KIT EDI #27857 INCLUDES:

REF #	DESCRIPTION	QTY
N/A	HEX CAP SCREW, 3/8"-16 X 1 1/2"	2
N/A	LOCK WASHER, 3/8"	2
N/A	HEX NUT, 3/8"-16	2

1200MP REPLACEMENT DRUMS

REF #	DESCRIPTION	PART#	QTY
7	1200MP DRUM SHELL	MIX245466	1

1220MP REPLACEMENT DRUMS

REF #	DESCRIPTION	PART#	QTY
7	1220MP RAM DUMP	27379	1

PARTS BREAKDOWN

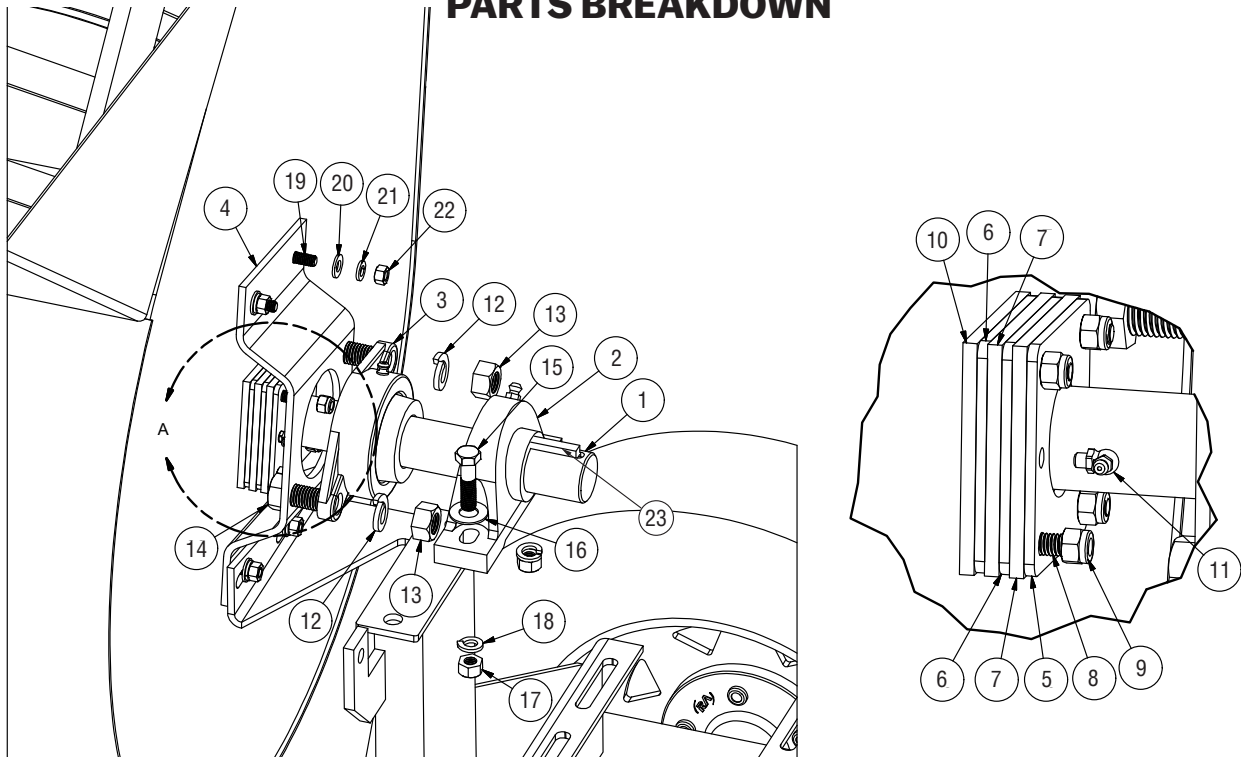

DRUM SHAFT FOR 1200/1220MP PARTS BREAKDOWN

REF #	DESCRIPTION	PART#	QTY
1	1200/1220MP DRUM SHAFT WELDMENT	MIX27908	1
2	PILLOW BLOCK BEARING, 1-3/4" ID	MIX27853	2
3	FLANGE MOUNT BEARING, 1-3/4" ID	MIX27860	2
4	BEARING SUPPORT BRACKET, MP MIXER	MIX27902	2
5	OUTER SEAL PLATE, MP MIXER	MIX27900	2
6	INNER SEAL PLATE, MP MIXER	MIX27901	4
7	DRUM SEAL, MP MIXER	MIX27904	4
8	CARRIAGE BOLT, 3/8"-16 X 2"	*	8
9	LOCKING NYLON NUT, 3/8"-16	*	8
10	INNER DRUM SEAL, MP MIXER	WX2158	2
11	GREASE ZERK, 1/8" NPT, 90 DEG.	*	2
12	LOCK WASHER, 3/4"	*	4
13	HEX NUT, 3/4"-10	*	4
14	HEX CAP SCREW, 3/4"-10 X 1 3/4"	*	4
15	HEX CAP SCREW, 1/2"-13 X 2"	*	4
16	FLAT WASHER, 1/2"	MIX70707	4
17	HEX NUT, 1/2"-13	MIX70563	4
18	LOCK WASHER, 1/2"	MIX70655	4
19	CARRIAGE BOLT, 3/8"-16 X 1 1/4"	MIX70906	8
20	FLAT WASHER, 3/8"	MIX70703	8
21	LOCK WASHER, 3/8"	MIX70649	8
22	HEX NUT, 3/8"-16	MIX70553	8
23	KEY STOCK, 3/8" SQ X 2	MIX71022	1

*COMMON HARDWARE CAN BE PURCHASED LOCALLY

PARTS BREAKDOWN

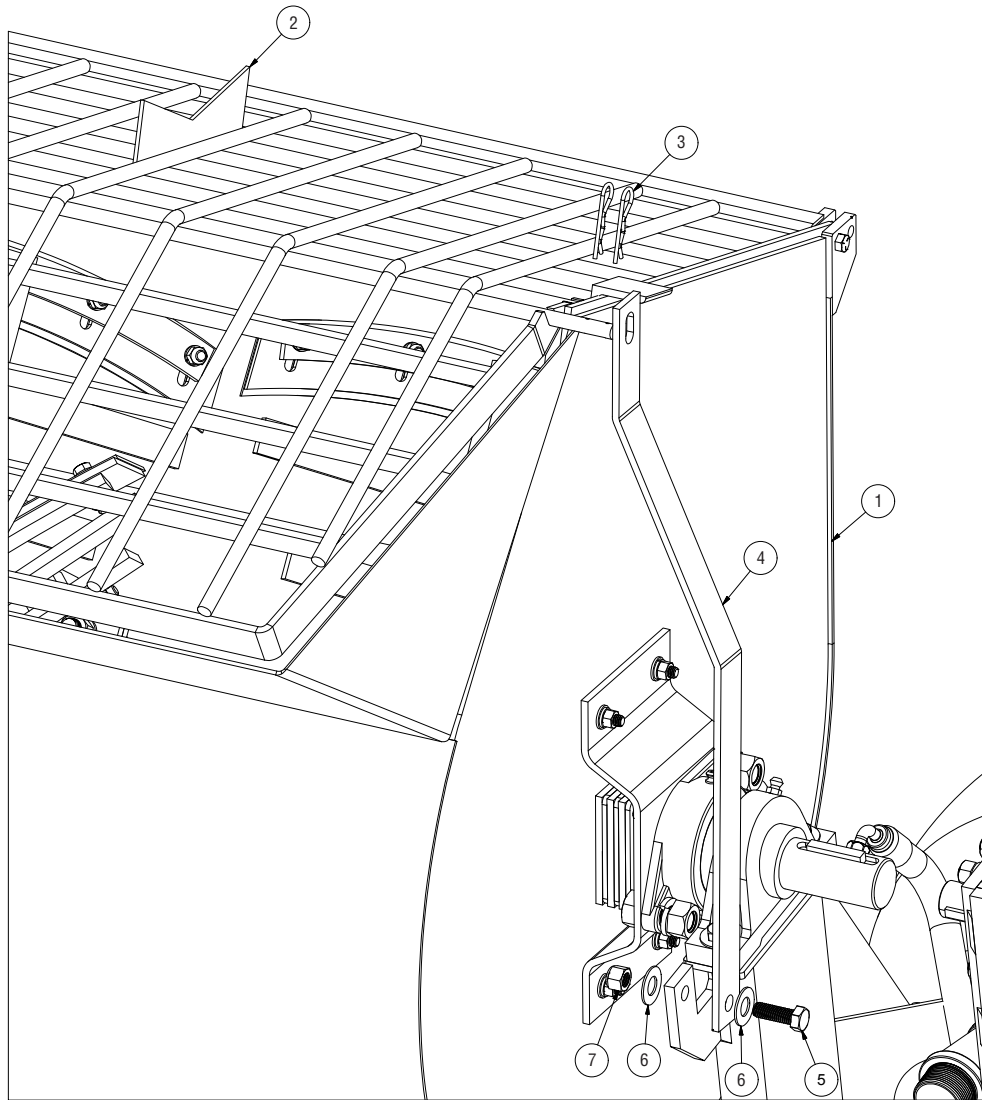

GRILL KIT, 1620MP EDI#27856 INCLUDES:

REF #	DESCRIPTION	QTY
2	1620MP GRILL WELDMENT	1
3	SPRING CLIP FOR LOCKING PIN	2
4	GRILL SAFETY LATCH, MP MIXER	1
5	HEX CAP SCREW, 1/2"-13 X 1 1/2"	1
6	FLAT WASHER, 1/2"	2
7	LOCKING NYLON NUT, 1/2"-13	1

GRILL HINGE HDW KIT EDI #27857 INCLUDES:

REF #	DESCRIPTION	QTY
N/A	HEX CAP SCREW, 3/8"-16 X 1 1/2"	2
N/A	LOCK WASHER, 3/8"	2
N/A	HEX NUT, 3/8"-16	2

1620MP REPLACEMENT DRUM

REF #	DESCRIPTION	PART#	QTY
1	1620MP DRUM WELDMENT	27380	1

PARTS BREAKDOWN

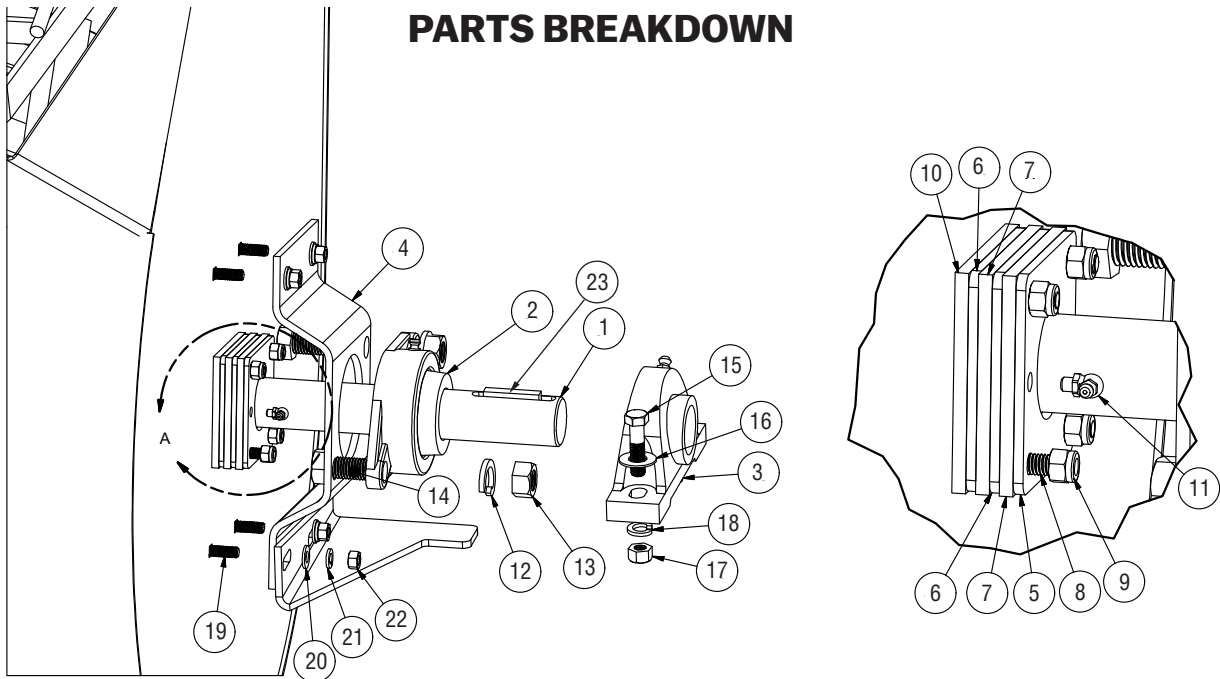

DRUM SHAFT FOR 1620MP PARTS BREAKDOWN

REF #	DESCRIPTION	PART#	QTY
1	1620MP DRUM SHAFT WELDMENT	R0590	1
2	FLANGE MOUNT BEARING, 1 3/4" ID	MIX27860	2
3	PILLOW BLOCK BEARING, 1 3/4" ID	MIX27853	2
4	BEARING SUPPORT BRACKET, MP MIXER	MIX27902	2
5	OUTER SEAL PLATE, MP MIXER	MIX27900	2
6	INNER SEAL PLATE, MP MIXER	MIX27901	4
7	DRUM SEAL, MP MIXER	MIX27904	4
8	CARRIAGE BOLT, 3/8"-16 X 2	*	8
9	HEX NUT, NYLON INSERT, 3/8"-16 X 2	*	8
10	INNER DRUM SEAL, MP MIXER	WX2158	2
11	GREASE ZERK, 1/8" NPT, 90 DEG.	*	2
12	LOCK WASHER, 3/4"	*	4
13	HEX NUT, 3/4"-10	*	4
14	HEX CAP SCREW, 3/4"-10 X 1 3/4"	*	4
15	HEX CAP SCREW, 1/2"-13 X 2"	*	4
16	FLAT WASHER, 1/2"	MIX70707	4
17	HEX NUT, 1/2"-13	MIX70563	4
18	LOCK WASHER, 1/2"	MIX70655	4
19	CARRIAGE BOLT 3/8"-16 X 1 1/4"	MIX70906	8
20	FLAT WASHER, 3/8"	MIX70703	8
21	LOCK WASHER, 3/8"	MIX70649	8
22	HEX NUT, 3/8"-16	MIX70553	8
23	KEY STOCK, 3/8" SQ X 2	MIX71022	1

*COMMON HARDWARE CAN BE PURCHASED LOCALLY

PARTS BREAKDOWN

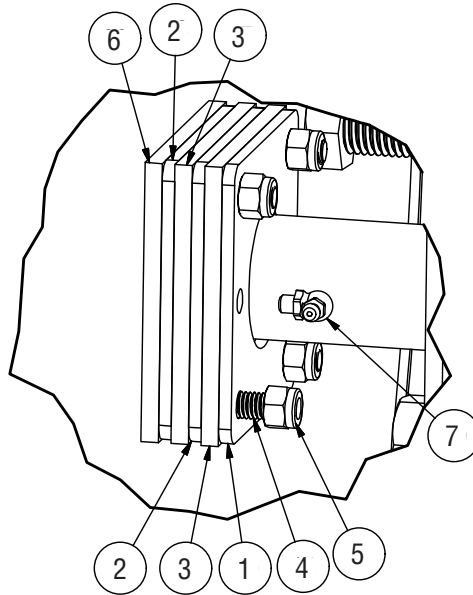

COMPLETE SEAL FOR ALL MP EDI# 27858 INCLUDES:

REF #	DESCRIPTION	QTY
1	OUTER SEAL PLATE, MP MIXER	2
2	INNER SEAL PLATE, MP MIXER	4
3	DRUM SEAL, MP MIXER	4
4	CARRIAGE BOLT, 3/8"-16 X 2"	8
5	LOCKING NYLON NUT, 3/8"-16	8
6	INNER DRUM SEAL, MP MIXER	2
7	GREASE ZERK, 1/8" NPT, 90 DEG.	2

800MP MIXING ARM ASSEMBLY

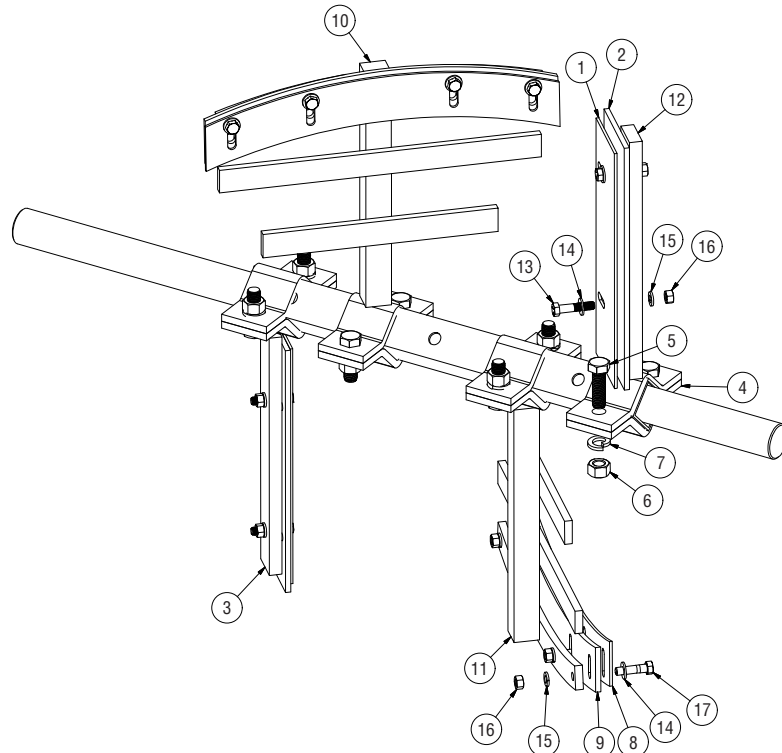

WIPER REPLACEMENT KITS FOR ALL MP MIXERS

REF #	DESCRIPTION	PART#	QTY
1	SIDE STEEL MIXING BLADE, MP MIXER (2 BLADES)	MIX27837	1
2	RUBBER SIDE SCRAPER, MP MIXER (2 BLADES)	MIX27838	1
8	STEEL MIXING BLADE, MP MIXER (2 BLADES)	MIX27841	1
9	RUBBER MIXING BLADE, MP MIXER (2 BLADES)	MIX27840	1
N/A	WIPER REPLACEMENT HARDWARE (4 BOLTS, 4 FLAT WASHERS, 4 LOCK WASHERS, 4 NUTS)	MIX27842	1

800MP MIXING ARM ASSEMBLY PARTS BREAKDOWN

REF #	DESCRIPTION	PART#	QTY
1	SIDE STEEL MIXING BLADE	MIX5088	2
2	RUBBER SIDE SCRAPER	MIX5089	2
3	ENGINE END SIDE WIPER	MIX245465	1
4	MIXING ARM CAP	MIX245461	4
5	HEX CAP SCREW, 5/8"-11 X 2"	MIX71195	8
6	HEX NUT, 5/8"-11	MIX70567	8
7	LOCK WASHER, 5/8"	MIX70657	8
8	STEEL MIXING BLADE	MIX5643	2
9	RUBBER MIXING BLADE	MIX5585	2
10	ENGINE END MIXING ARM	MIX245463	1
11	TOW END MIXING ARM	MIX245460	1
12	TOW END SIDE WIPER	MIX245464	1
13	HEX CAP SCREW, 3/8"-16 X 1 3/4"	MIX70456	4
14	FLAT WASHER, 3/8"	MIX70703	12
15	LOCK WASHER, 3/8"	MIX70649	12
16	HEX NUT, 3/8"-16	MIX70553	12
17	HEX CAP SCREW, 3/8"-16 X 1 1/2"	MIX70249	8

PARTS BREAKDOWN 1200/1220MP MIXING ARM ASSEMBLY

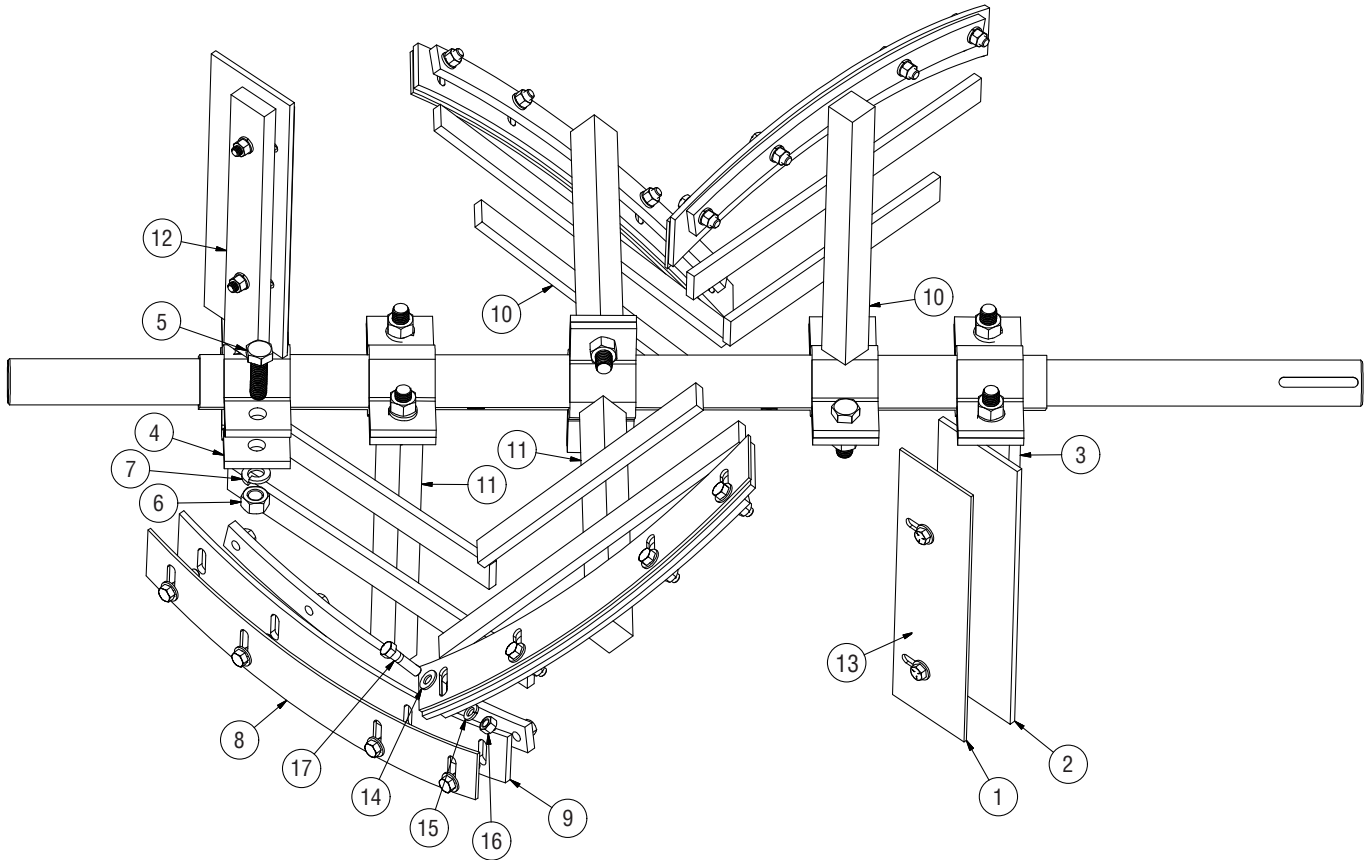

REF #	DESCRIPTION	PART#	QTY
1	SIDE STEEL MIXING BLADE	MIX5088	2
2	RUBBER SIDE SCRAPER	MIX5089	2
3	ENGINE END SIDE WIPER	MIX245465	1
4	MIXING ARM CAP	MIX245461	4
5	HEX CAP SCREW, 5/8"-11 X 2"	MIX71195	10
6	HEX NUT, 5/8"-11	MIX70567	10
7	LOCK WASHER, 5/8"	MIX70657	10
8	STEEL MIXING BLADE	MIX5643	4
9	RUBBER MIXING BLADE	MIX5585	4
10	ENGINE END MIXING ARM	MIX245463	2
11	TOW END MIXING ARM	MIX245460	2
12	TOW END SIDE WIPER	MIX245464	1
13	HEX CAP SCREW, 3/8"-16 X 1 3/4"	MIX70456	4
14	FLAT WASHER, 3/8"	MIX70703	20
15	LOCK WASHER, 3/8"	MIX70649	20
16	HEX NUT, 3/8"-16	MIX70553	20
17	HEX CAP SCREW, 3/8"-16 X 1 1/2"	MIX70249	16

PARTS BREAKDOWN 1620MP MIXING ARM ASSEMBLY

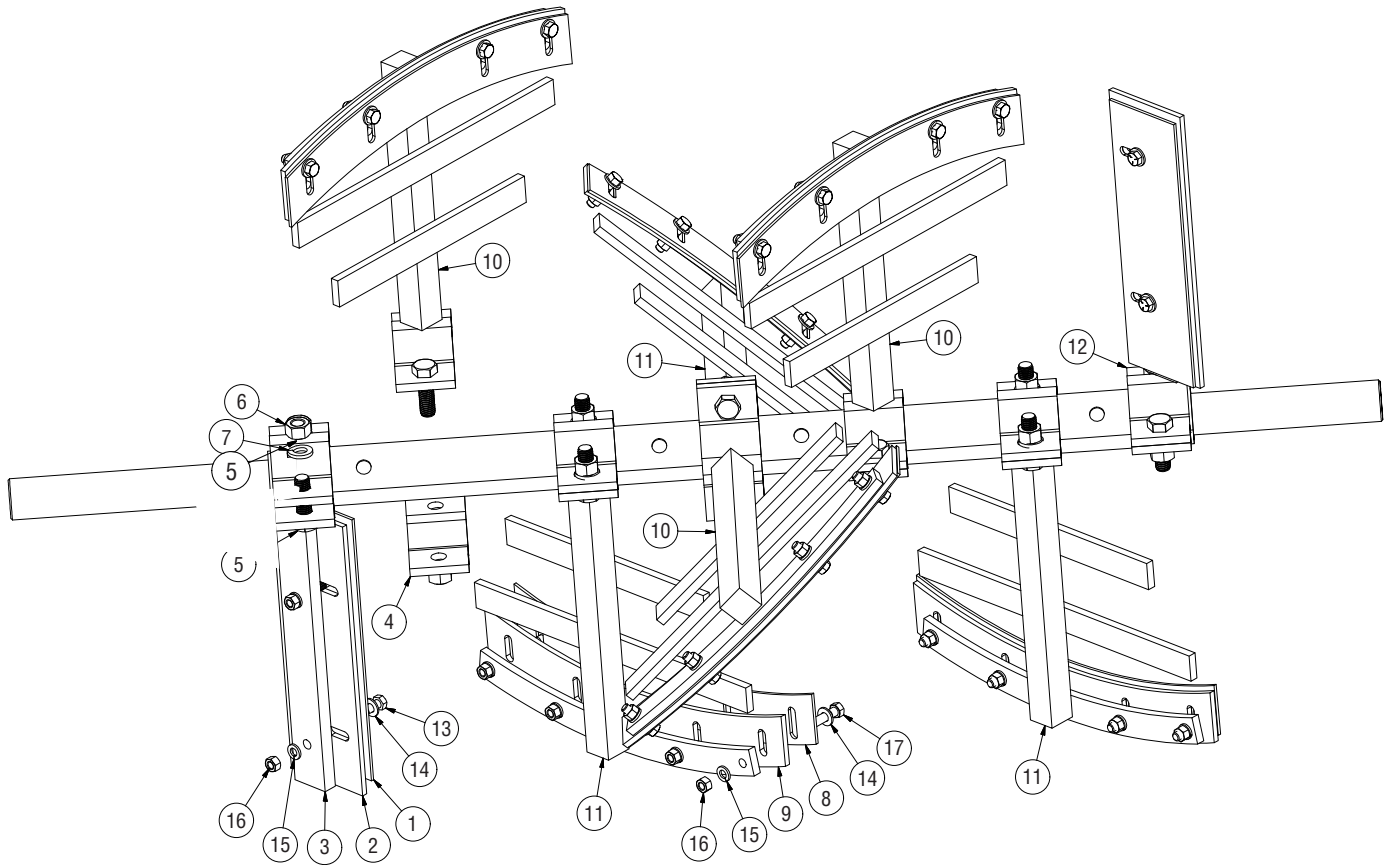

REF #	DESCRIPTION	PART#	QTY
1	SIDE STEEL MIXING BLADE	MIX5088	2
2	RUBBER SIDE SCRAPER	MIX5089	2
3	ENGINE END SIDE WIPER	MIX245465	1
4	MIXING ARM CAP	MIX245461	6
5	HEX CAP SCREW, 5/8"-11 X 2"	MIX71195	14
6	HEX NUT, 5/8"-11	MIX70567	14
7	LOCK WASHER, 5/8"	MIX70657	14
8	STEEL MIXING BLADE	MIX5643	6
9	RUBBER MIXING BLADE	MIX5585	6
10	ENGINE END MIXING ARM	MIX245463	3
11	TOW END MIXING ARM	MIX245460	3
12	TOW END SIDE WIPER	MIX245464	1
13	HEX CAP SCREW, 3/8"-16 X 1 3/4"	MIX70456	4
14	FLAT WASHER, 3/8"	MIX70703	28
15	LOCK WASHER, 3/8"	MIX70649	28
16	HEX NUT, 3/8"-16	MIX70553	28
17	HEX CAP SCREW, 3/8"-16 X 1 1/2"	MIX70249	24

PARTS BREAKDOWN

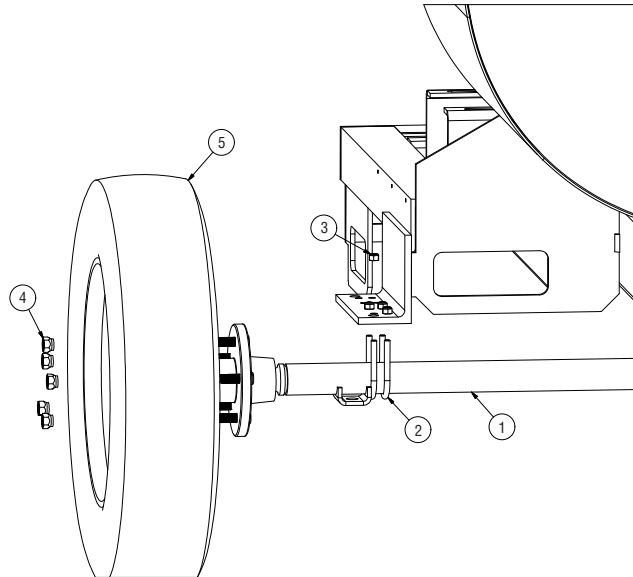

AXLE PARTS BREAKDOWN (DECEMBER 2017-CURRENT)

REF #	DESCRIPTION	PART#	QTY
1	SOLID AXLE ASSEMBLY	27309	1
2	U-BOLT, 5/16"-18 X 1 1/4" PIPE SIZE	*	4
3	LOCKING NYLON NUT, 5/16"-18	*	8

*COMMON HARDWARE CAN BE PURCHASED LOCALLY

LUGNUT KIT EDI #27819 INCLUDES:

REF #	DESCRIPTION	QTY
4	OPEN WHEEL NUT	10

WHEEL & TIRE EDI #27906 INCLUDES:

REF #	DESCRIPTION	QTY
5	WHEEL & TIRE	1

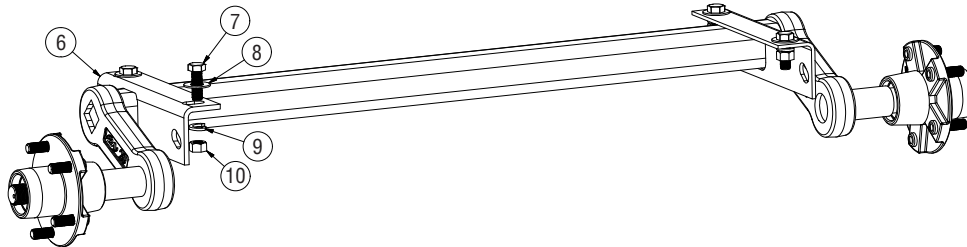

TORSION AXLE REPLACEMENT (PRE-DEC. 2017) EDI #27905 INCLUDES:

REF #	DESCRIPTION	PART#	QTY
6	TORSION AXLE ASSEMBLY (PRE-DEC. 2017)	MIX27905	1

HARDWARE FOR TORSION AXLE REPLACEMENT (PRE-DEC. 2017) EDI #27820 INCLUDES:

REF #	DESCRIPTION	QTY
7	HEX CAP SCREW, 1/2"-13 X 1 1/2	4
8	FLAT WASHER, 1/2"	4
9	LOCK WASHER, 1/2"	4
10	HEX NUT, 1/2"	4

PARTS BREAKDOWN

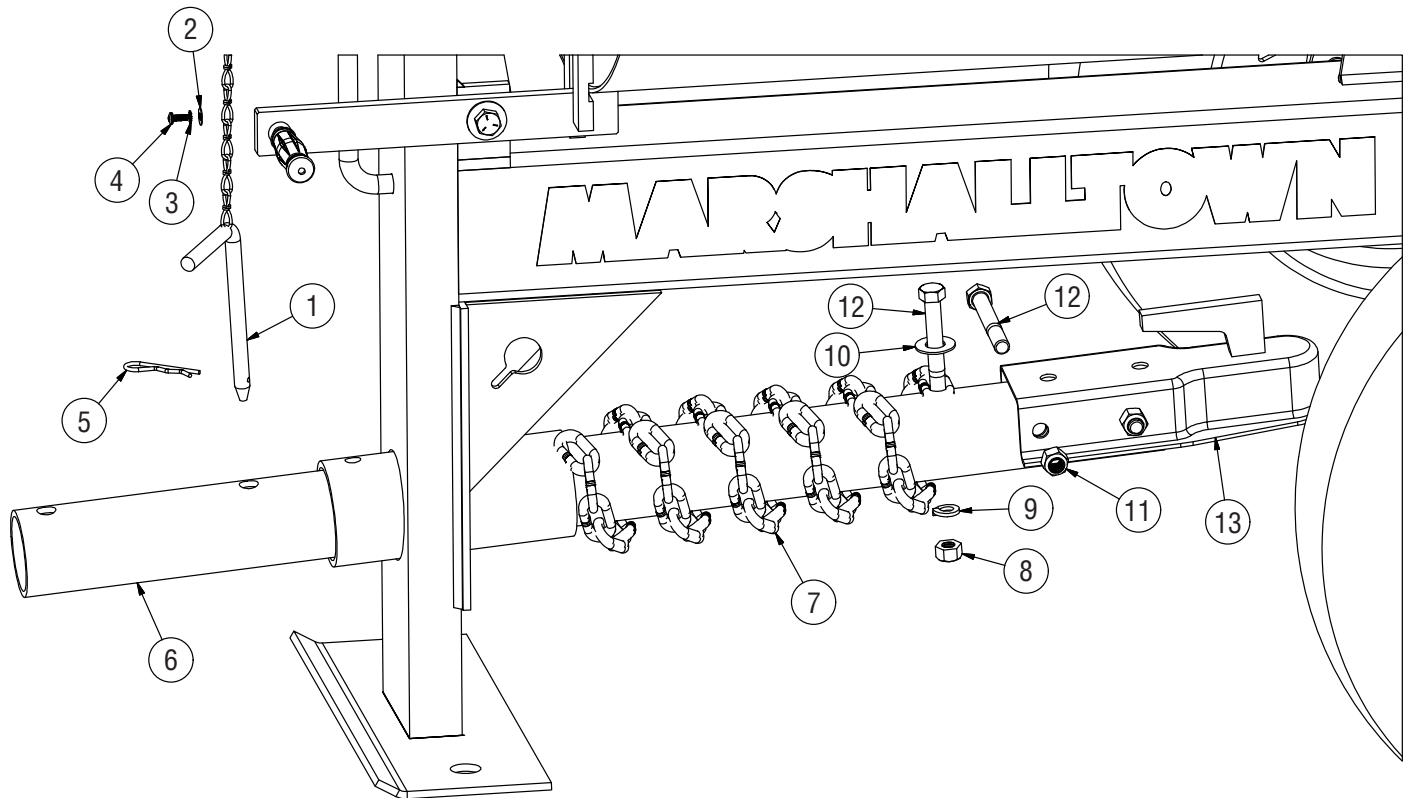

BALL TOW POLE EDI# 27818 INCLUDES:

REF #	DESCRIPTION	PART#	QTY
1	CHAIN & PIN ASSEMBLY ASSEMBLY FOR TOW POLE	MIX27821	1
2	FLAT WASHER, 1/4"	*	1
3	LOCK WASHER, 1/4"	*	1
4	HEX CAP SCREW, 1/4"-20 X 3/4"	MIX70097	1
5	SPRING CLIP FOR LOCKING PIN	MIX2776	1
6	TOW POLE FOR BALL HITCH	R0546	1
7	CHAIN, 1/4" X 58"L W/ 7/16" HOOK	MIX245480A	2
8	HEX NUT, 1/2"	MIX70563	1
9	LOCK WASHER, 1/2"	MIX70655	1
10	FLAT WASHER, 1/2"	MIX70707	1
11	LOCKING NYLON NUT, 1/2" X 13	WR1133	2
12	HEX CAP SCREW, 1/2"-13 X 4"	MIX71234	3
13	2" BALL COUPLER	WX1893	1

*COMMON HARDWARE CAN BE PURCHASED LOCALLY

PARTS BREAKDOWN

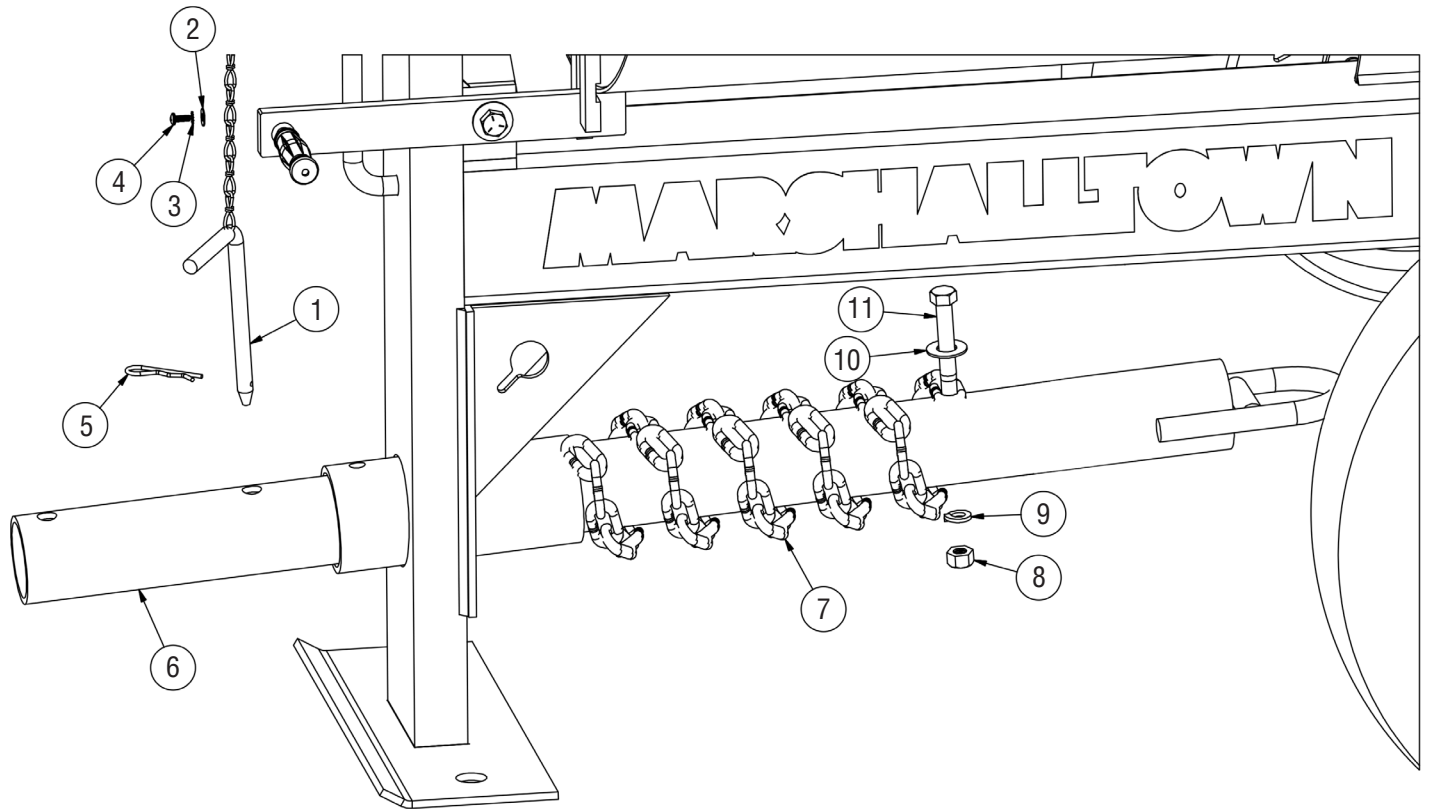

PINTLE TOW POLE EDI# 27808 INCLUDES:

REF #	DESCRIPTION	PART#	QTY
1	CHAIN & PIN ASSEMBLY FOR TOW POLE	MIX27621	1
2	FLAT WASHER, 1/4"	*	1
3	LOCK WASHER, 1/4"	*	1
4	HEX CAP SCREW, 1/4"-20 X 3/4"	MIX70097	1
5	SPRING CLIP FOR LOCKING PIN	MIX2776	1
6	TOW POLE FOR PINTLE HITCH	MIX232491	1
7	CHAIN, 1/4" X 58"L W/ 7/16" HOOK	MIX245480A	2
8	HEX NUT, 1/2"	MIX70563	1
9	LOCK WASHER, 1/2"	MIX70655	1
10	FLAT WASHER, 1/2"	MIX70707	1
11	HEX CAP SCREW, 1/2"-13 X 4"	MIX71234	1

**COMMON HARDWARE CAN BE PURCHASED LOCALLY*

PARTS BREAKDOWN

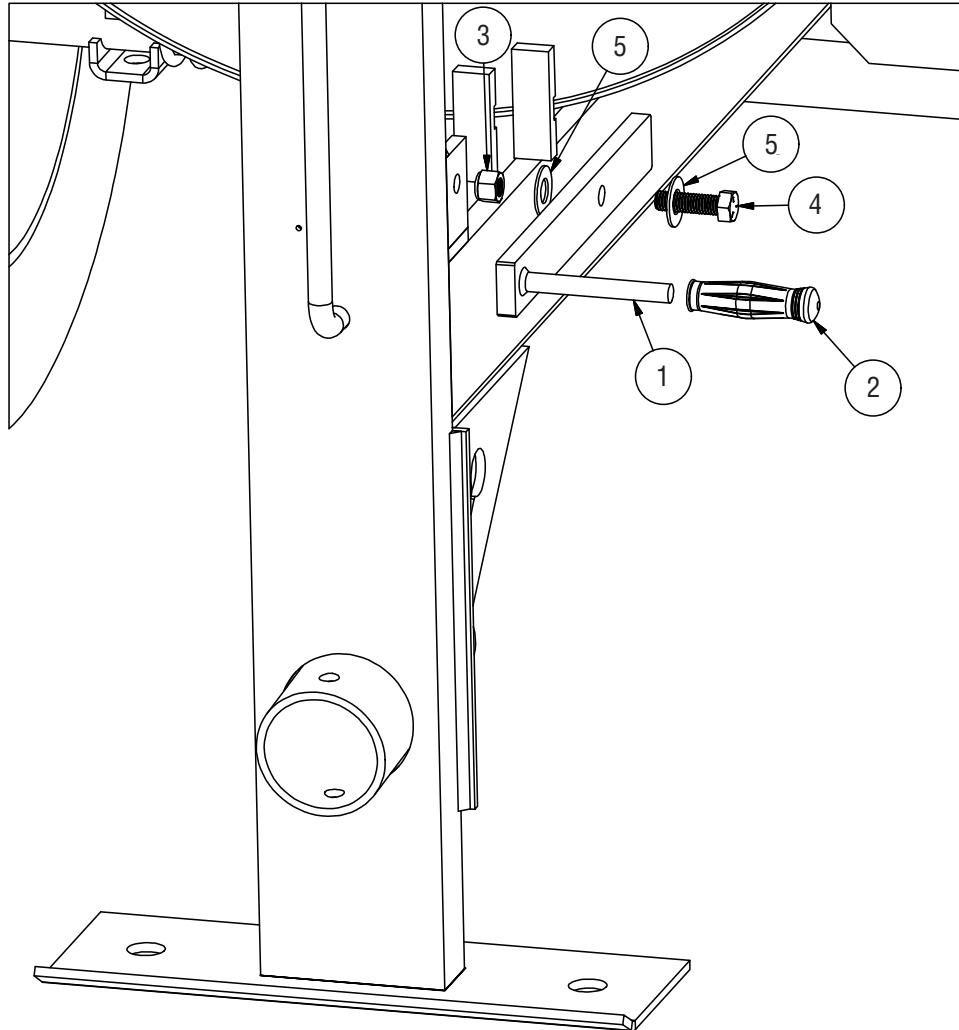

DRUM LOCK KIT EDI #27830 INCLUDES:

REF #	DESCRIPTION	QTY
1	HANDLE, DRUM LOCK	1
2	GRIP, 1/2"	1
3	HEX NUT, 1/2" - 13	1
4	HEX CAP SCREW, 1/2"-13 X 1 1/2"	1
5	FLAT WASHER, 1/2"	2

PARTS BREAKDOWN

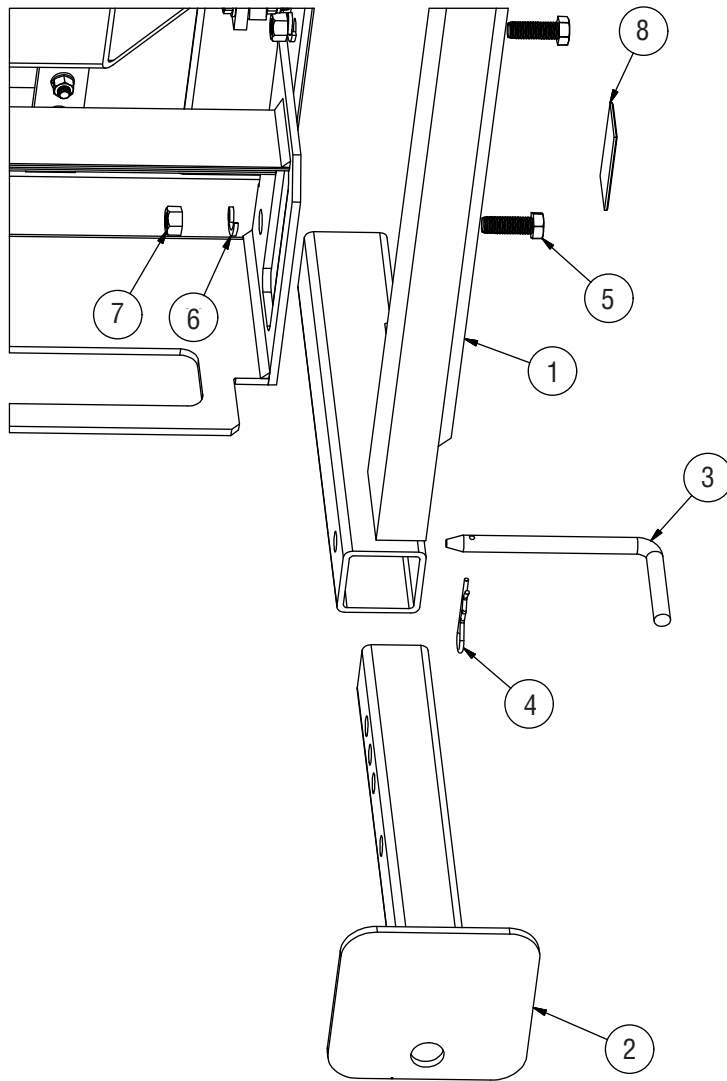

OUTRIGGER KIT EDI #27849 INCLUDES:

REF #	DESCRIPTION	PART#	QTY
1	OUTRIGGER KIT, MAIN WELDMENT	R0560	1
2	OUTRIGGER KIT, FOOT WELDMENT	MIX27881	2
3	PIN, 1/2" X 8 13/16"	MIX232257	2
4	SPRING CLIP FOR LOCKING PIN	MIX2776	2
5	HEX CAP SCREW, 1/2"-13 X 1 1/2"	MIX70343	4
6	LOCK WASHER, 1/2"	MIX70655	4
7	HEX NUT, 1/2"-13	MIX70563	4

REFLECTOR KIT EDI #27847 INCLUDES:

REF #	DESCRIPTION	QTY
8	REFLECTOR	2

PARTS BREAKDOWN

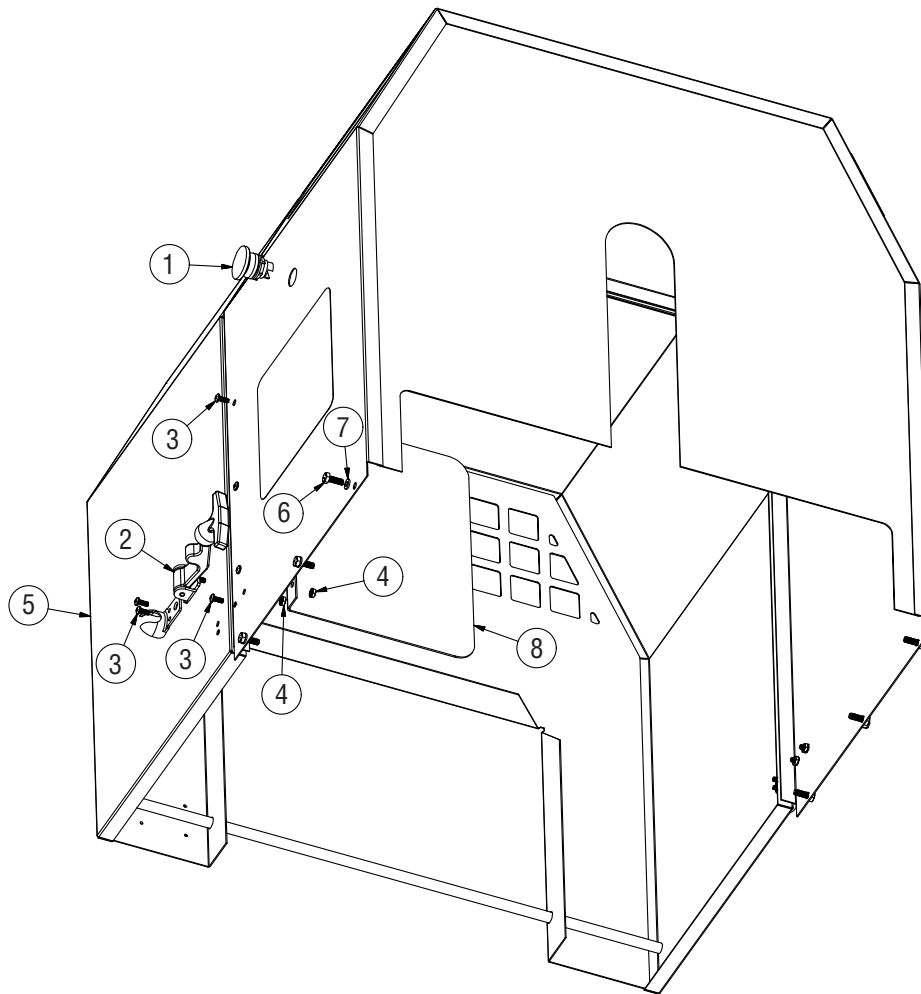

KILL SWITCH, ALL MP GAS EDI# 23666 INCLUDES:

REF #	DESCRIPTION	TY
1	STOP BUTTON, MUSHROOM HEAD, TURN	1

LATCH WITH HARDWARE EDI# 27846 INCLUDES:

REF #	DESCRIPTION	QTY
2	ENGINE HOUSE LATCH	2
3	PHILLIPS PAN HEAD MACHINE SCREW, 10-24 X 1/2"	6
4	KEPS NUT, 10-24	6

ENGINE HOUSE W/HDW EDI #27844 INCLUDES:

REF #	DESCRIPTION	QTY
5	ENGINE HOUSE, MP MIXER	1
6	HEX CAP SCREW 1/4"-20 X 3/4"	6
7	LOCK WASHER, 1/4"	6

DIVIDER KIT EDI #27845 INCLUDES:

REF #	DESCRIPTION	QTY
4	KEPS NUT, 10-24	3
3	PHILLIPS PAN HEAD MACHINE SCREW, 10-24 X 1/2"	3
8	ENGINE HOUSE DIVIDER	1

PARTS BREAKDOWN

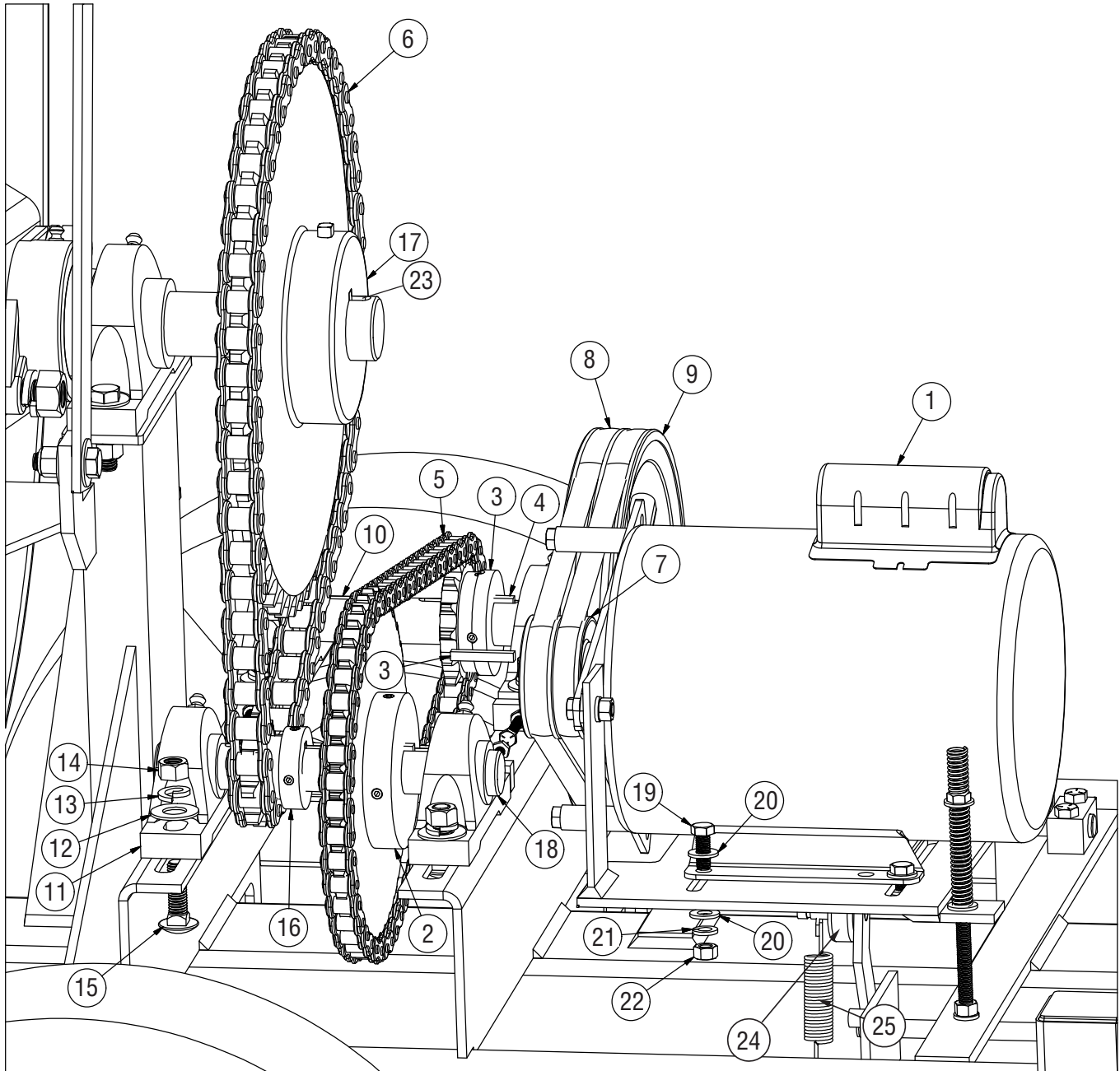

MOTOR, ELEC. EDI# 22162 INCLUDES:

REF #	DESCRIPTION	QUANTITY
1	MOTOR, 3HP, 1PH, 60-HZ, LEESON #131534.00	1

800/1200MP ELECTRIC ENGINE DRIVE ASSEMBLY PARTS BREAKDOWN

REF #	DESCRIPTION	PART#	QUANTITY
2	LARGE INTERMEDIATE SPROCKET	MIX27893	1
3	SMALL INTERMEDIATE SPROCKET	MIX27876	1
4	KEY STOCK, 1/4" SQ X 1 3/4"	*	5
5	#60 RIVETED ROLLER CHAIN	MIX27895	1
6	#80 RIVETED ROLLER CHAIN	MIX27894	1
7	PULLEY	MIX5118	1
8	V-BELT, 5L420	MIX5398	2
9	SHEAVE	MIX27875	1
10	DRIVE SHAFT, MP MIXER	MIX27863	1
11	BEARING, PILLOW BLOCK	MIX27868	4
12	FLAT WASHER, 1/2"	MIX70707	8
13	LOCK WASHER, 1/2"	MIX70655	8
14	HEX NUT, 1/2"-13	MIX70563	8
15	1/2"-13 X 1 3/4" CARRIAGE BOLT	*	8
16	SMALL SPROCKET	MIX27871	1
17	LARGE SPROCKET	MIX27874	1
18	DUMP SIDE DRIVE SHAFT, ELECTRIC MP MIXER	R5686	1
19	HEX CAP SCREW, 3/8"-16 X 1"	MIX70235	4
20	FLAT WASHER, 3/8"	MIX70703	4
21	LOCK WASHER, 3/8"	MIX70649	4
22	HEX NUT, 3/8"-16	MIX70553	4
23	KEY STOCK, 3/8" SQ X 2"	MIX71022	1

*COMMON HARDWARE CAN BE PURCHASED LOCALLY

CLUTCH ROLLER & SPRING

REF #	DESCRIPTION	PART#	QUANTITY
24	CLUTCH ROLLER	MIX211689	1
25	OVERCENTER SPRING	MIX232266	1

PARTS BREAKDOWN

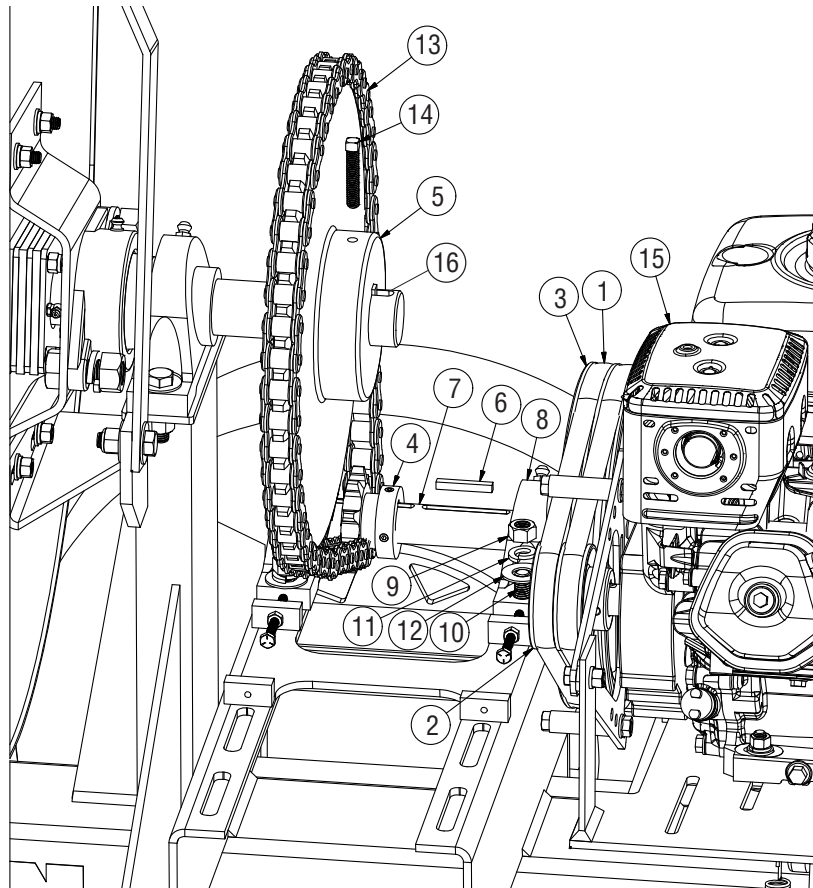

800/1200MP GAS ENGINE DRIVE ASSEMBLY PARTS BREAKDOWN

REF #	DESCRIPTION	PART#	QTY
1	V-BELT, B41	MIX27872	2
2	SMALL PULLEY	MIX245721	1
3	LARGE PULLEY	MIX27875	1
4	SMALL SPROCKET	MIX27871	1
5	LARGE SPROCKET	MIX27874	1
6	KEY STOCK, 1/4" X 1 3/4"	*	3
7	DRIVE SHAFT, MP MIXER	MIX27863	1
8	BEARING, PILLOW BLOCK	MIX232421	2
9	HEX NUT, 1/2"-13	MIX70563	4
10	1/2"-13 X 1 3/4" CARRIAGE BOLT	*	4
11	LOCK WASHER, 1/2"	MIX70655	4
12	FLAT WASHER, 1/2"	MIX70707	4
13	#80 RIVETED ROLLER CHAIN	MIX27894	1
14	SQ. HEAD SETSCREW, 3/8"-16 X 2"	MIX27873	2
16	KEY STOCK, 3/8" SQ X 2"	MIX71022	1

*COMMON HARDWARE CAN BE PURCHASED LOCALLY

ENGINE, HONDA GX240 FOR 800/1200MP EDI# 22586 INCLUDES:

REF #	DESCRIPTION	QTY
15	ENGINE, GX240 #GX240K1HA W/6:1 REDUCTION	1

PARTS BREAKDOWN

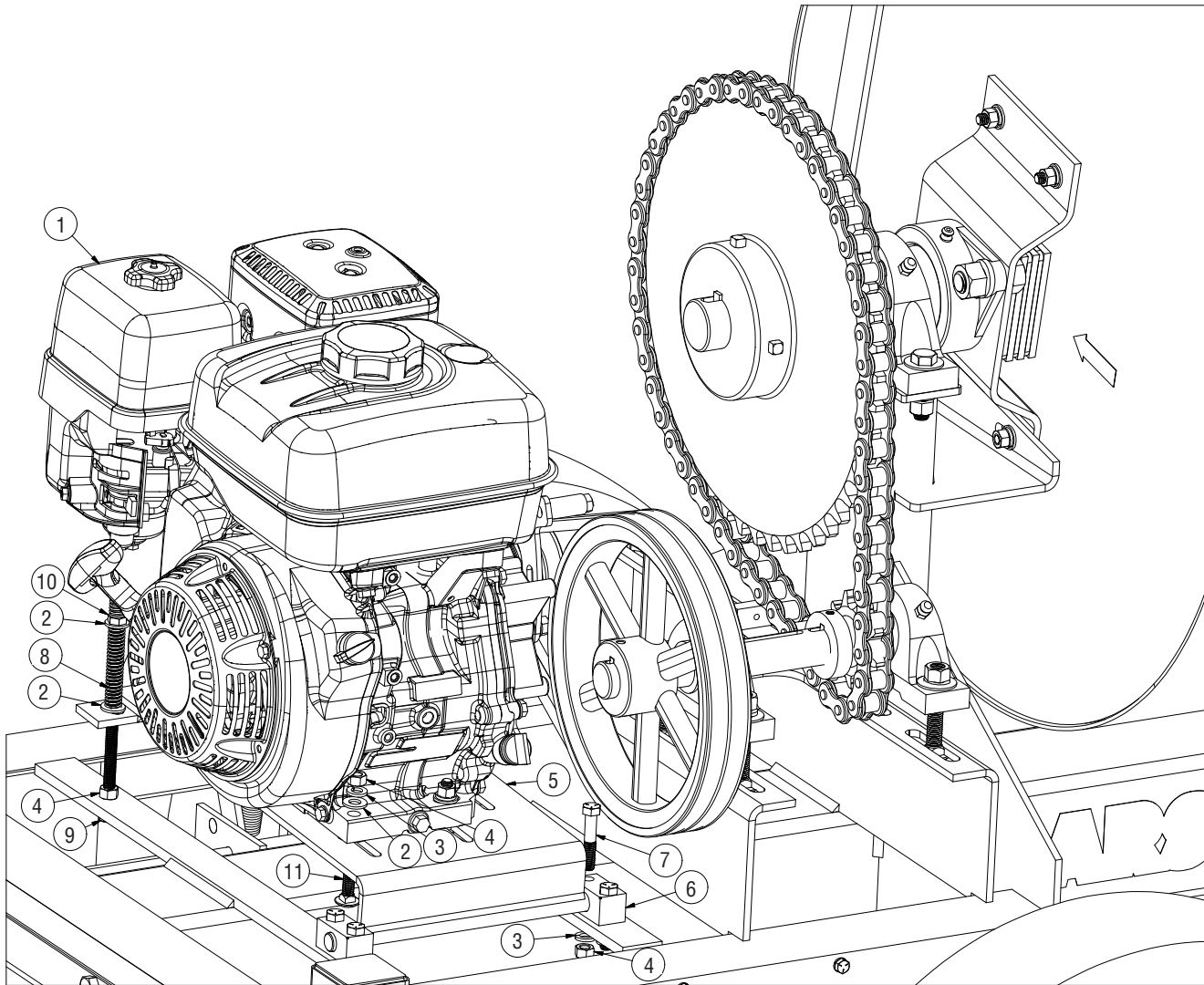

800/1200MP ENGINE TABLE ASSEMBLY PARTS BREAKDOWN

REF #	DESCRIPTION	PART#	QTY
2	FLAT WASHER, 3/8"	*	6
3	LOCK WASHER, 3/8"	MIX70649	8
4	HEX NUT, 3/8"-16	MIX70553	9
5	ENGINE MOTOR BASE, MP MIXER	MIX27899	1
6	MOUNT, PIVOT	MIX232548	2
7	HEX CAP SCREW, 3/8"-16 X 2"	*	4
8	SPRING	MIX23156	1
9	LOCKING NYLON NUT, 3/8"-16	*	1
10	HEX CAP SCREW, 3/8"-16 X 7"	*	1
11	CARRIAGE BOLT, 3/8" - 16 X 1 3/4"	*	4

*COMMON HARDWARE CAN BE PURCHASED LOCALLY

ENGINE, HONDA GX240 FOR 800/1200MP EDI# 22586 INCLUDES:

REF #	DESCRIPTION	QTY
1	ENGINE, GX240 #GX240K1HA W/6:1 REDUCTION	1

PARTS BREAKDOWN

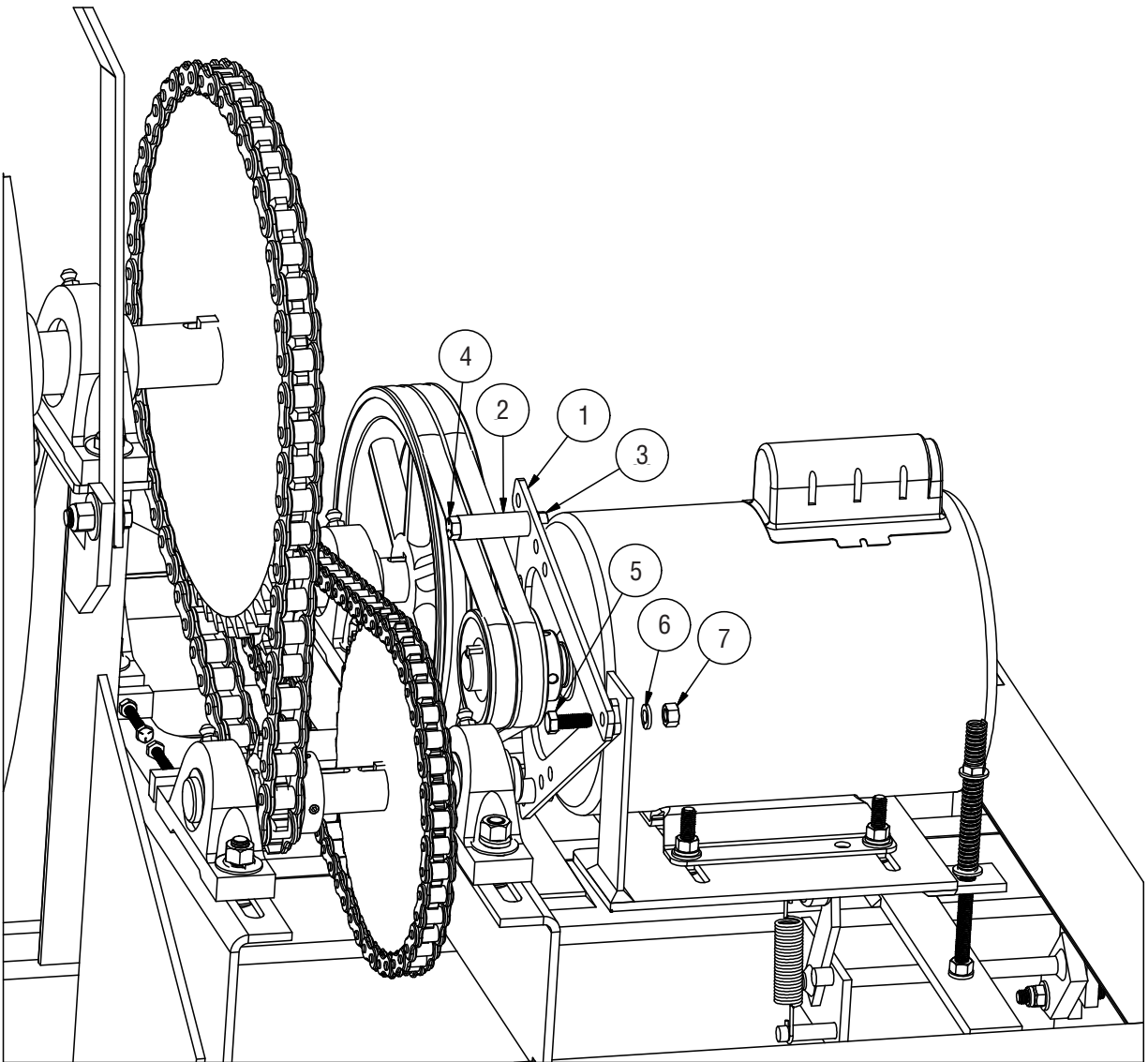

BELT FINGER W/HDW KIT FOR 800/1200MP #27865 INCLUDES:

REF #	DESCRIPTION	QTY
1	BELT FINGER	2
2	PIVOT TUBE	2
3	JAM NUT, 3/8"-16	4
4	HEX CAP SCREW, 3/8"-16 X 3"	2
5	HEX CAP SCREW, 3/8"-16 X 1"	2
6	LOCK WASHER, 3/8"	2
7	HEX NUT, 3/8"-16	2

PARTS BREAKDOWN

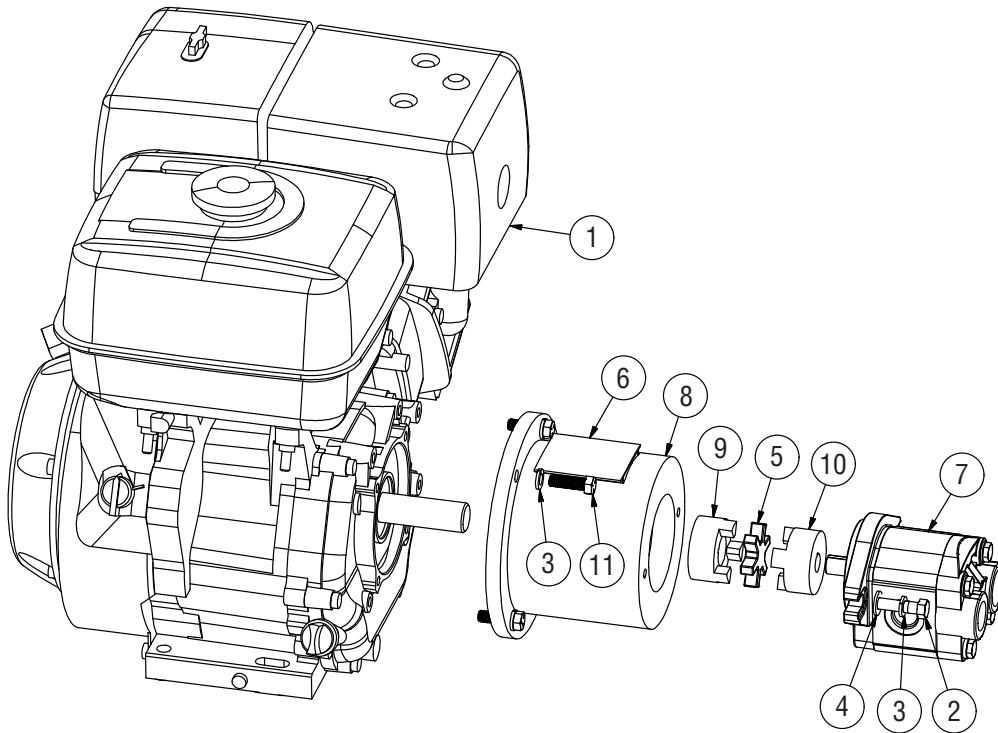

ENGINE, GX390 FOR 1220/1620MP EDI# 22854 INCLUDES:

REF #	DESCRIPTION	QTY
1	ENGINE, GX390 HONDA GX390K12QA2	1

1220/1620MP GAS ENGINE HYD PUMP ASSEMBLY PARTS BREAKDOWN

REF #	DESCRIPTION	PART#	QTY
2	HEX CAP SCREW, 3/8" - 16 X 1 1/2"	MIX70249	2
3	LOCK WASHER, 3/8"	MIX70649	6
4	FLAT WASHER, 3/8"	MIX70703	2
5	SPIDER SOX	MIX755P40007	1
6	COVER (FOR GAS AND ELECTRIC)	MIX755P40010	1
7	HYD PUMP FOR GAS MIXER	MIX245960	1
8	MOUNT, PUMP	MIX755P40004	1
9	COUPLING, MOTOR	MIX755P40005	1
10	COUPLING, PUMP	MIX755P40006	1
11	HEX CAP SCREW, 3/8"-16 X 1 1/4"	*	4

**COMMON HARDWARE CAN BE PURCHASED LOCALLY*

PARTS BREAKDOWN

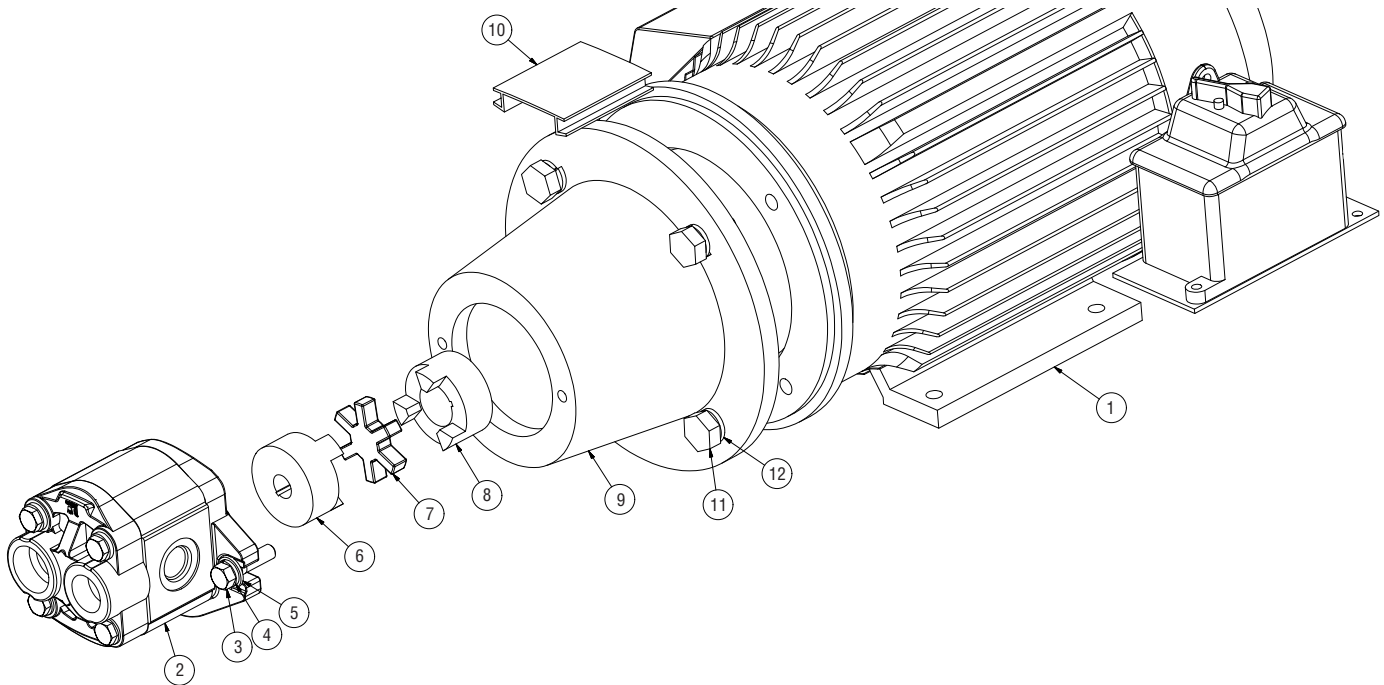

MOTOR, 5HP ELEC. FOR 1220/1620MP EDI# 22990 INCLUDES:

REF #	DESCRIPTION	QTY
1	MOTOR, 5HP LEESON #131633, 1 PHASE	1

MOTOR, 7.5HP ELEC. FOR 1220, 1620MP EDI# 27869 INCLUDES:

REF #	DESCRIPTION	QTY
1	MOTOR, 7.5HP LEESON #132313, 3 PHASE	1

1220/1620MP ELECTRIC ENGINE HYD PUMP ASSEMBLY PARTS BREAKDOWN

REF #	DESCRIPTION	PART#	QTY
2	HYDRAULIC PUMP FOR ELECTRIC MIXER	MIX755P40048	1
3	HEX CAP SCREW, 3/8"-16 X 1.5"	MIX70249	2
4	LOCK WASHER, 3/8"	MIX70649	2
5	FLAT WASHER, 3/8"	MIX70703	2
6	COUPLING, PUMP	WX1762	1
7	SPIDER SOX	MIX755P40083	1
8	COUPLING, MOTOR	MIX755P40082	1
9	MOUNT, HYD PUMP	MIX755P40079	1
10	COVER (FOR GAS AND ELECTRIC)	MIX755P40010	1
11	HEX CAP SCREW, 1/2"-13 X 1 1/4"	MIX70339	4
12	LOCK WASHER, 1/2"	MIX70655	4

PARTS BREAKDOWN

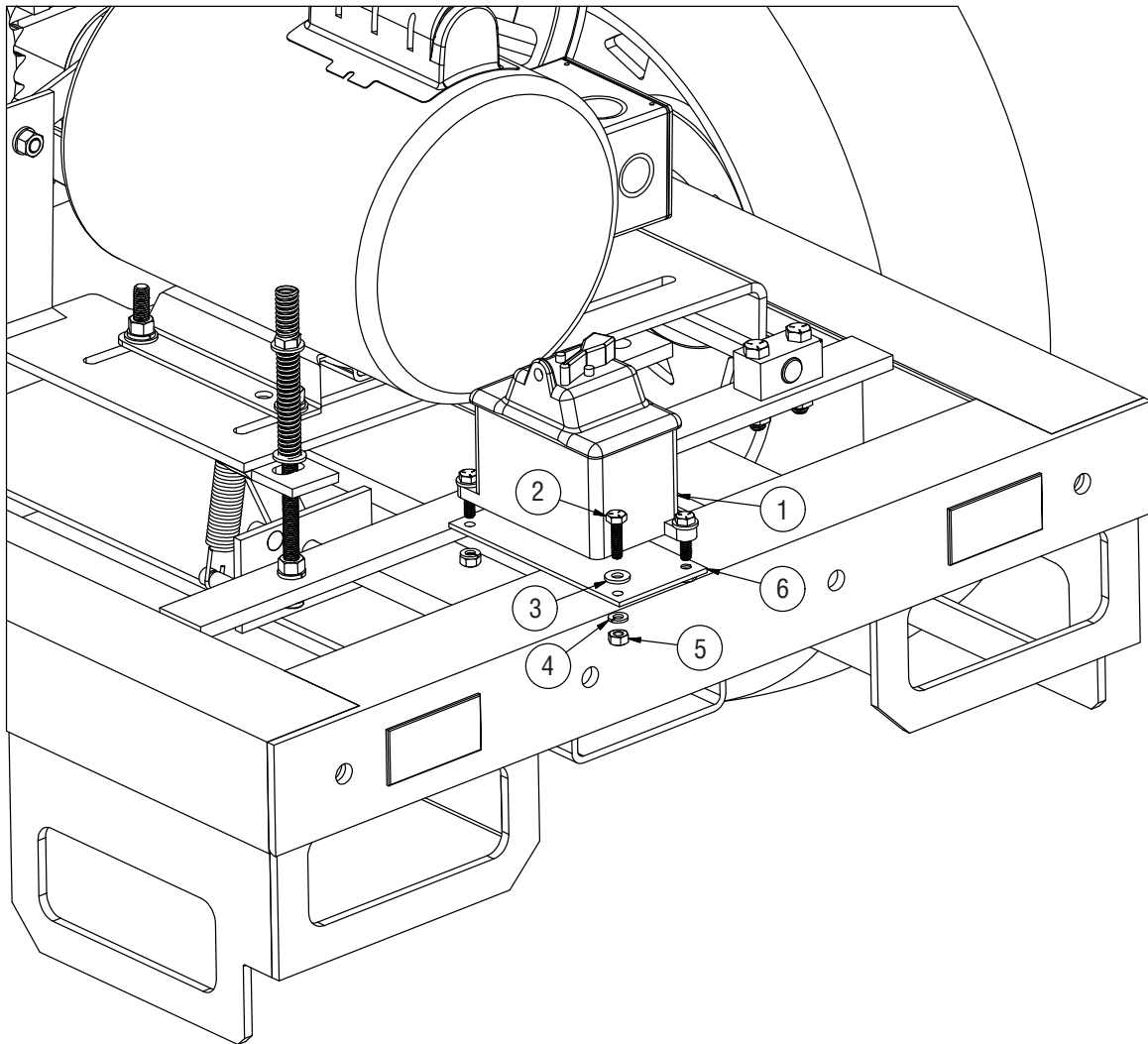

ON/OFF SWITCH ASSEMBLY PARTS BREAKDOWN

REF #	DESCRIPTION	PART#	QTY
1	1PH ON/OFF SWITCH 3PH ON/OFF SWITCH	WX2123 27804	1 1
2	HEX CAP SCREW, 1/4"-20 X 1"	*	3
3	FLAT WASHER, 1/4"	*	3
4	LOCK WASHER, 1/4"	*	3
5	HEX NUT, 1/4"-20	*	3
6	SWITCH MOUNTING BRACKET	WX2165	1

**COMMON HARDWARE CAN BE PURCHASED LOCALLY*

1220/1620MP HYDRAULIC COMPONENTS

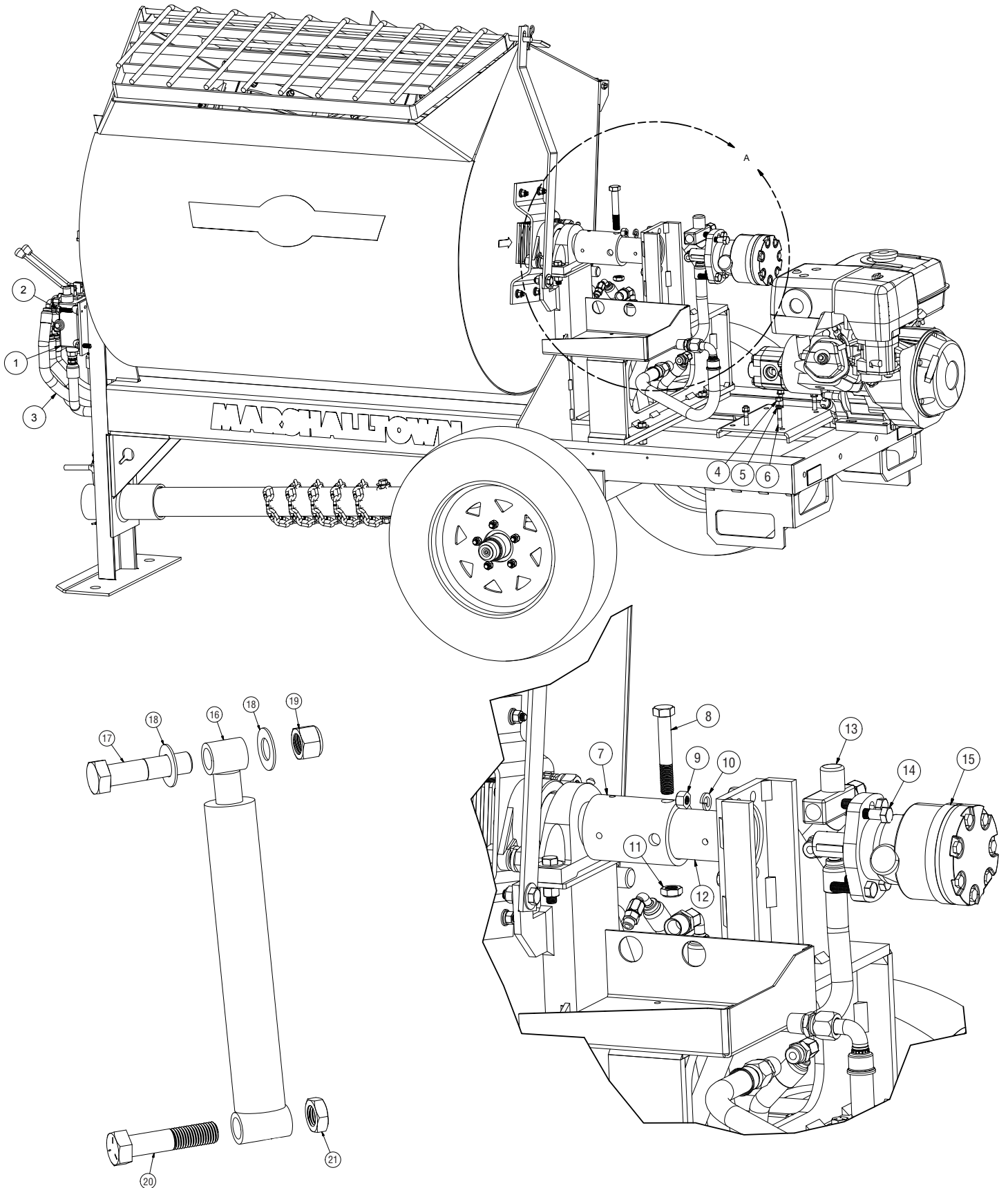

1220/1620MP HYDRAULIC COMPONENT PARTS BREAKDOWN

REF #	DESCRIPTION	PART#	QTY
1	VALVE (2017- CURRENT) VALVE (PRE-2017)	MIX27788 MIX750P40459	1
2	HEX CAP SCREW, 3/8"-16 X 1 1/4"	*	4
3	1220MP HOSE KIT (2016-CURRENT) 1220MP HOSE KIT (2014-2015) 1620MP HOSE KIT (2014-CURRENT)	MIX27787 MIX27910 MIX27911	1
4	HEX NUT, 3/8"-16	MIX70553	4
5	LOCK WASHER, 3/8"	MIX70649	4
6	HEX CAP SCREW, 3/8"-16 X 2 1/4"	*	4
7	DRIVE COUPLING	MIX245230	1
8	HEX CAP SCREW, 5/8"-11 X 4"	*	1
9	HEX NUT, 1/2"-13	MIX70563	4
10	LOCK WASHER, 1/2"	MIX70655	4
11	LOCKING NYLON NUT, 5/8"-11	*	1
12	HYDRAULIC MOTOR COUPLING	MIX245962	1
13	FLOW VALVE	MIX245961	1
14	HEX CAP SCREW, 1/2"-13 X 2"	*	4
15	HYDRAULIC MOTOR	MIX245957	1
16	HYDRAULIC CYLINDER	MIX750P40458	1
17	HEX CAP SCREW, 1"-8 X 4 1/4"	*	1
18	FLAT WASHER, 1"	*	2
19	LOCKING NYLON NUT, 1"-8	*	1
20	HEX CAP SCREW, 1"-8 X 4 1/2"	*	1
21	HEX JAM NUT, 1"-8	*	1

*COMMON HARDWARE CAN BE PURCHASED LOCALLY

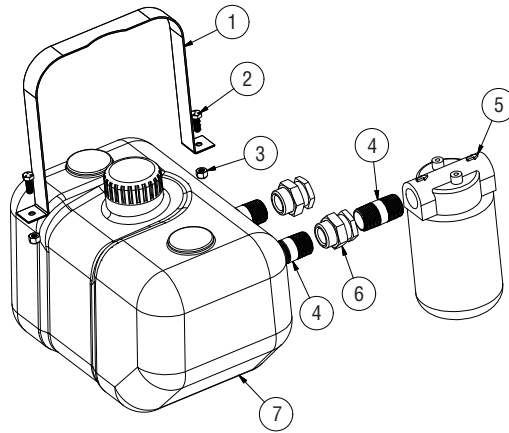

1220/1620MP POLY HYDRAULIC RESERVOIR (2018-CURRENT) PARTS BREAKDOWN

REF #	DESCRIPTION	PART#	QTY
1	RESERVOIR STRAP	MIX28618	1
2	HEX CAP SCREW, 1/4"-20 X 3/4"	*	2
3	LOCKING NYLON NUT, 1/4"-20	*	2
4	NIPPLE, 3/4"	MIX28619	3
5	HYDRAULIC OIL FILTER	MIX245959	1
6	BULKHEAD FITTING, 3/4" NPT	MIX28620	2
7	2.5 GALLON POLY RESERVOIR	MIX28617	1

*COMMON HARDWARE CAN BE PURCHASED LOCALLY

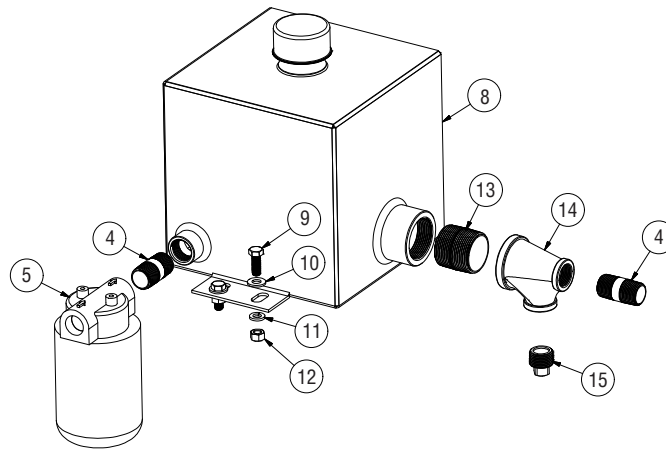

1220/1620MP STEEL HYDRAULIC RESERVOIR (PRE-2018) PARTS BREAKDOWN

REF #	DESCRIPTION	PART#	QTY
4	NIPPLE, 3/4" NPT	MIX28619	2
5	HYDRAULIC OIL FILTER	MIX245959	1
8	2.5 GALLON STEEL RESERVOIR	MIX27907	1
9	HEX CAP SCREW, 3/8"-16 X 1"	*	4
10	FLAT WASHER, 3/8"	MIX70703	4
11	LOCK WASHER, 3/8"	MIX70649	4
12	HEX NUT, 3/8"-16	MIX70553	4
13	NIPPLE, 1 1/2" NPT	*	1
14	TEE, 1 1/2" X 3/4"	*	1
15	SOLID PLUG, 3/4" NPT	*	1

*COMMON HARDWARE CAN BE PURCHASED LOCALLY

MAINTENANCE SCHEDULE



WARNING!

- Keep hands out of the drum at all times when the engine/motor is turning.
- Observe all safety decals. Replace any safety decals that cannot be read.
- Always use guards and safety devices in their intended manner.
- Disconnect spark plug wire or electric cord before cleaning inside the drum.
- Hydraulic fluid may be hot. Allow fluid and equipment to cool before servicing.

ENGINES AND MOTORS:

For information on maintenance of your engine or motor, refer to the information provided by the manufacturer.

WEEKLY MAINTENANCE:

- Grease drum shaft bearings, drum seals, and drum bearing hangers.
- Grease drive shaft bearings.
- Check the tension and condition of the belts. Tighten or replace as necessary.
- If applicable, check all hydraulic hoses and fittings for leaks. Fix any leaks before operation.

MONTHLY MAINTENANCE:

- Check all bearings and seals for damage. Replace as necessary.

YEARLY MAINTENANCE:

- Repack wheel bearings with grease and replace seals.

NOTICE: Record the model and serial numbers in the spaces provided.

Mixer serial numbers can be located on the nameplate

Engine Model, Type and Code numbers are located on the blower housing, cylinder head or backplate

Product Model Number: _____

Product Serial Number: _____

Engine/Motor Model Number: _____

Engine/Motor Code Number: _____

Purchase Date: _____

Dealer Purchased From: _____

Dealer Address: _____

Dealer Phone Number: _____

TROUBLESHOOTING

GAS ENGINE WON'T START:

1. Check for sufficient fuel.
2. Check oil level. Engines have an "Oil Alert" feature, which prevents them from starting when the oil level is low.
3. Was engine choked when starting?
4. Is engine flooded?
5. Check spark plug. (Clean and check gap)
6. If engine still will not start, consult the engine owner's manual or take it to an authorized service center.

ELECTRIC ENGINE WON'T START:

1. Make sure the motor is wired correctly for the supply voltage. Wiring information can be found on the motor nameplate or inside the wiring box.
2. Check plugs, fuses, and circuit breakers. The circuit should be rated for AT LEAST the full load current of the motor.
3. Make sure the mixer is not jammed or overloaded when starting up. This can lead to repeated blown fuses or tripped circuit breakers.

ENGINE/MOTOR STARTS BUT PADDLES WILL NOT TURN:

HYDRAULIC DRIVE MODELS

1. Make sure the mixer is not jammed. A broken mixing arm can prevent the entire shaft from turning.
2. Check the adjustment on the flow control.
3. Make sure the shear bolt is still intact on the coupler between the hydraulic motor and the drum shaft.
4. Verify hydraulic fluid levels and check the filter.

MECHANICAL DRIVE MODELS

1. Check the belts for wear, oil, or grease. Replace them if necessary.
2. Loosen the bolts that hold the engine in place. Slide the engine away from the drive shaft to tighten the belts; then re-tighten the bolts. Be careful not to over-tighten the belts or the clutch will not disengage.
3. Make sure the clutch mechanism is moving the idler pulley or engine base when the clutch lever is moved.
4. Make sure that gears are meshing and not slipping on the drive or drum shafts.



104 S. 8th Ave., Marshalltown, IA
Phone 800-888-0127 / 641-753-0127
Fax 800-477-6341 / 641-753-6341
www.MARSHALLTOWN.com
WS3022