

Instructions for Replacement of the SST/RCT Camlock Pin (Models #220, #226, #520, #526)

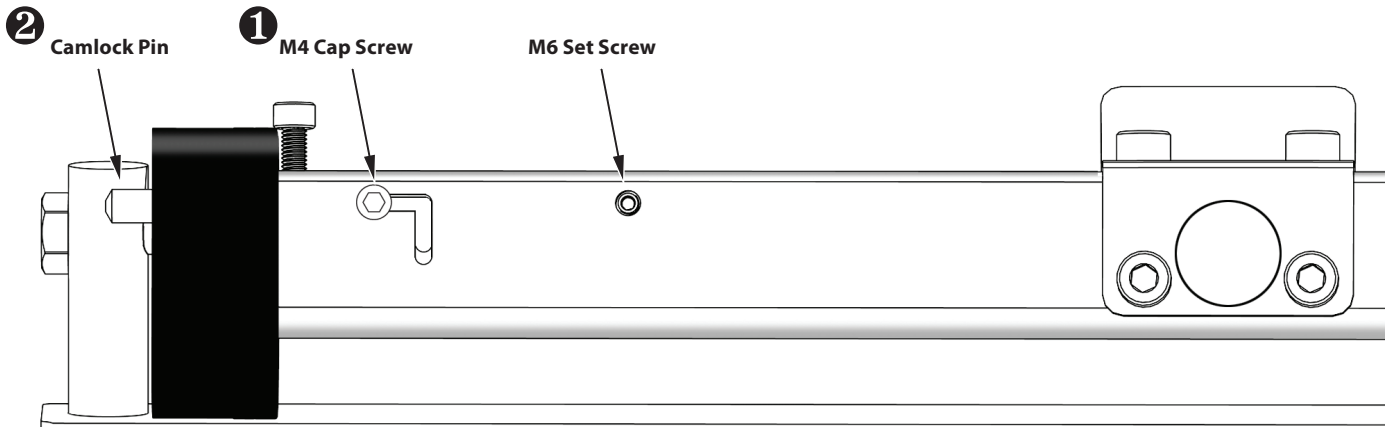

- 1 Unscrew and remove the M4 Cap Screw with the 3mm allen wrench (*included*).
- 2 Roll the camshaft forward (push the handle down) and pull the Camlock pin from the hole in the camshaft.
Note: If Camlock pin is stuck, see below.

Caution: *Spring pressure may push the Camlock pin out of the machine*

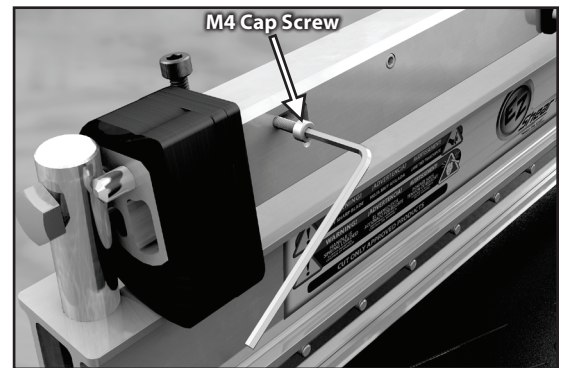

- 3 Insert the new Camlock pin and screw the M4 Cap Screw back into place. Tighten securely with the 3mm allen wrench.



If the Camlock pin is stuck:

- A. **IMPORTANT:** Remove the M6 Set Screw (*roughly in the middle of the camshaft*) with the 3mm allen wrench (*included*).
- B. Turn the machine on its right side and let the Camlock spring fall out.
- C. Turn the machine on its left side, roll the camshaft forward (push the handle down until the blade is closed) and slide the 1/4" x 16" steel rod(s) (*included*) down the Camlock hole.
- D. Tap the Camlock pin out with the steel rod(s) and a hammer. Remove steel rod(s).
- E. Turn the machine upright. Screw the M6 Set Screw (*see Step A*) back in.
- F. Put the spring back into the Camlock hole from the left side.
- G. Insert the new Camlock pin and screw the M4 Cap Screw back into place. Tighten securely with the 3mm allen wrench.

