

MAGNUM RIGID FOAM CUTTER

Set-up & Operation Instructions

CAUTION: SHARP BLADE!

SET UP:

- 1) Recommended stand: Two (2) four ft (or longer) sawhorses with two 46" to 47" long 2X4's attached as shown.

Alternatives:

- Clamp to tabletop with 8" C clamp.
- Screw or bolt to work bench.

Best set 4" to 6" below waist height

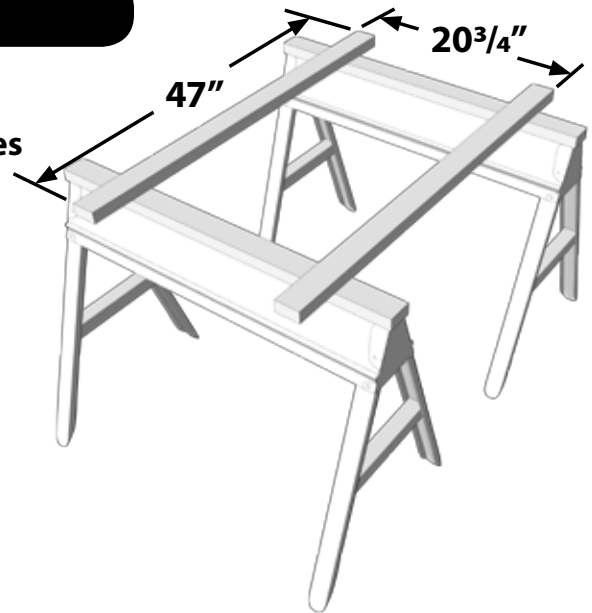

- 2) Securely mount Cutter base to preferred stand. Fasten with screws or clamps.

- 3) Remove the 1/2" bolts **A** from the side supports **B**

- 4) Unfold one of the side supports **B** and lock in place with locking pin **C**

- 5) Slide the horizontal bar **D** through the upright side support **B** at least 6"

- 6) Slide the blade carriage assembly **E** onto the horizontal bar **D**. Leave at least 2" exposed on the unsupported end.

- 7) Unfold the other side support **F** and lock into place

- 8) Slide the horizontal bar **D** into the side support

- 9) Re-insert 1/2" bolts **A** into both supports and tighten locknuts

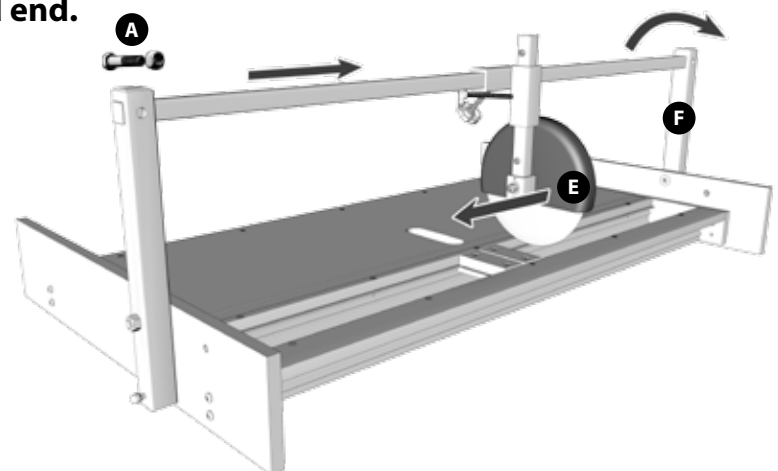
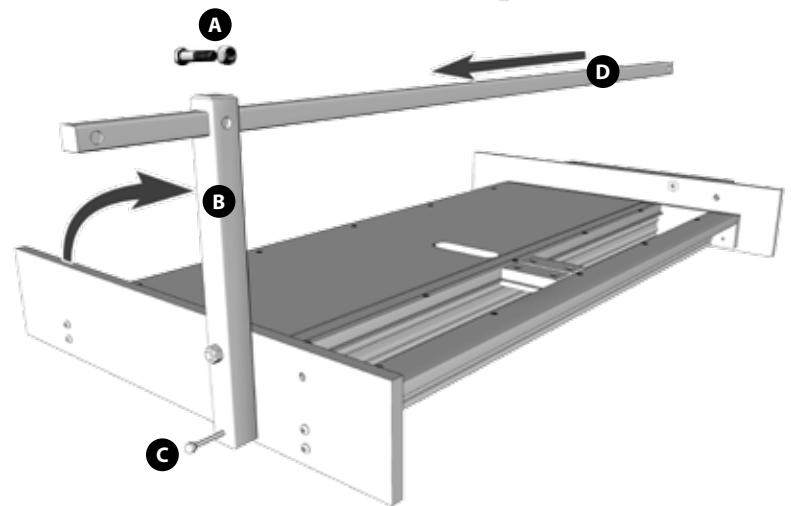

OPERATION/USE:

1) Remove Blade Cover (not shown)

2) Set Cut Width:

Loosen horizontal adjustment knob (A)
Move blade carriage (B) to desired position
Tighten horizontal adjustment knob (A)
Center support block (C) under blade

3) Set Cut Depth

Loosen height adjustment knob (D)

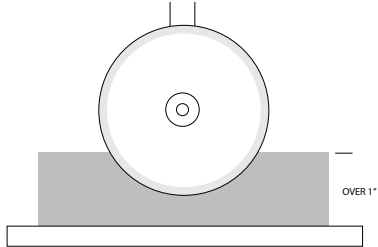

For products thicker than 1",
Lower blade to 1/2
of product thickness.

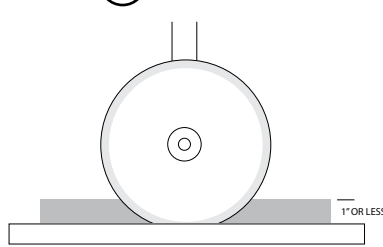

For products 1" or thinner,
Lower blade to 1/4"
below table surface.

Tighten height adjustment knob (D)

4) Set sheet of foam on tabletop and lightly press against left fence.

Push into blade with steady firm pressure

As the product moves beyond the table, have your helper pull lightly
to ensure a smooth cut.

To finish the cut, push with a piece of sacrificial material or
a push stick for the last 6" to avoid injury.

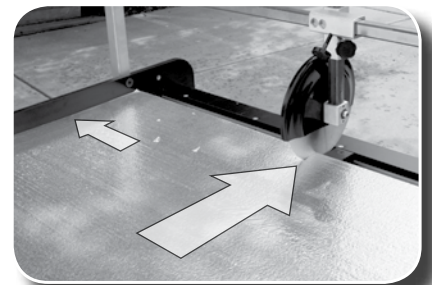

MAINTENANCE:

1) Several components of the Magnum Rigid Foam Cutter should be lubricated regularly with Slick Shot™, Grease, or Spray Oil, as shown.

2) To sharpen Blade:

- WEAR KEVLAR OR CUT RESISTANT LEATHER GLOVES.
- Lift blade to 1" above the table.
- Insert Furii™ diamond sharpener under blade.
- Rotate blade 3 times while applying pressure with sharpener.

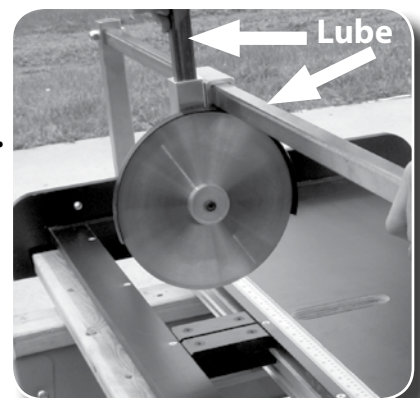

To Replace Blade:

- WEAR KEVLAR OR CUT RESISTANT LEATHER GLOVES
- Remove axle bolt with a 3/16" allen (Hex-Key) wrench and a 7/16" wrench
- Remove Blade
- Reassemble with New Blade



SAFETY

- 1) **SHARP BLADE** - This machine uses a razor sharp blade. Keep hands, feet, and other appendages away at all times.
- 2) Wear Kevlar™ or cut-resistant leather gloves when operating or servicing the blade.
- 3) This machine has several pinch points. Do not adjust or collapse machine when fingers are in the way.
- 4) Use the included fixed blade guard. Do not remove it.
Replace the blade cover whenever the machine is not in use.
- 5) To avoid tipping and/or rocking, only operate on a level, stable, flat surface.
- 6) Wear safety goggles and all other OSHA recommended safety gear when cutting.
- 7) For your safety, this machine should be operated by two competent individuals. Don't operate alone.