

GILSON MIXERS

**MORTAR-PLASTER MIXER
MODEL: 800MP-NEW STYLE**

OPERATOR'S GUIDE & PARTS MANUAL

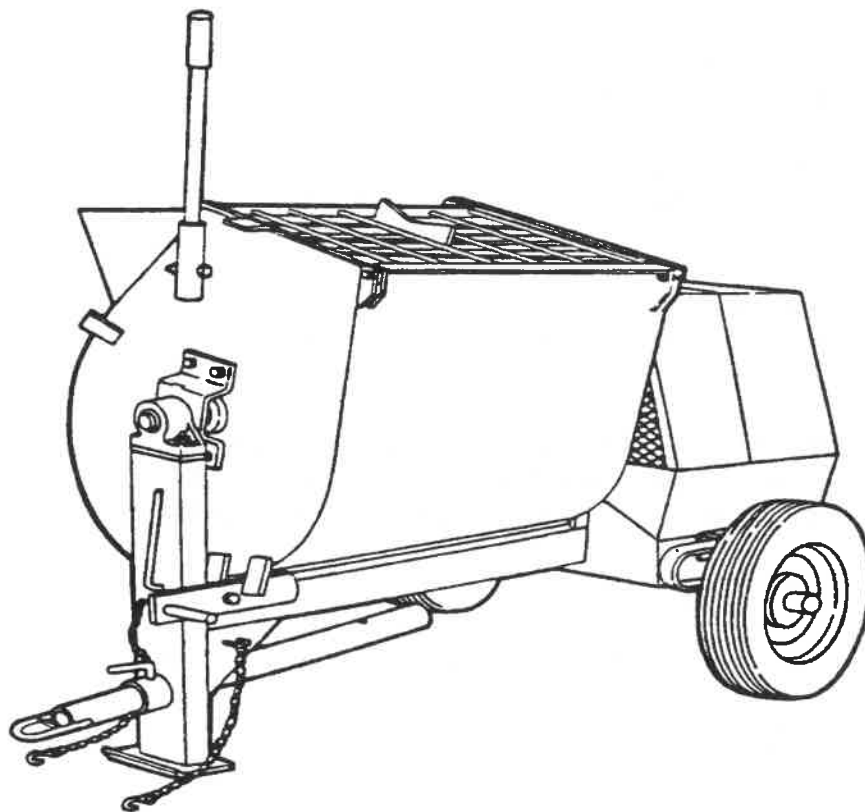

**GILSON MIXERS
BY**



4343 Easton Road · St. Joseph, MO 64503
816-233-4840 · 800-253-3676
Fax 816-233-4624 · 888-253-3676
E-Mail: cleform@ccp.com
Web Address: www.cleform.com

INTRODUCTION

This operator's manual has been prepared to provide the information you need to correctly operate and maintain your mixer. For maximum satisfaction, carefully read and follow the instructions in this manual. Should you need repair parts or service, refer to the parts breakdown on pages 7 through 18.

Information regarding operation and maintenance of the factory-installed engine or motor can be found in a separate engine/motor owner's manual supplied with the mixer. The manual prepared by the engine/motor manufacturer gives you the information necessary regarding engine adjustments, operation and maintenance. Should any questions arise concerning engine operation or service, contact the nearest engine/motor repair facility or dealer. For dealers in your area, consult the Yellow Pages under "Engines-Gasoline" or "Motors-Electric".

Be sure safety precautions are observed. Read and follow all safety and operating instructions in this operator's manual.

The replacement of any part on this product by other than the manufacturer's authorized replacement part may adversely affect the performance, durability, or safety of the product.

The manufacturer reserves the right to make changes on, or add improvements to its product at any time reserves the right to decide, upon its sole discretion and at any time, to discontinue a product.

NOTICE: Record the model and serial numbers of your unit (located on the nameplate) in the spaces provided below. Engine model, type and code numbers are located on the engine blower housing, cylinder head or back plate.

PRODUCT MODEL NUMBER: _____

PRODUCT SERIAL NUMBER: _____

ENGINE/MOTOR MODEL NUMBER: _____

ENGINE/MOTOR CODE NUMBER: _____

PURCHASE DATE: _____

DEALER PURCHASED FROM: _____

DEALER ADDRESS: _____

DEALER PHONE NUMBER: _____

TABLE OF CONTENTS

1. SAFETY PRECAUTIONS	2
2. ASSEMBLY AND PREOPERATIONAL CHECKS	2
3. CONTROLS AND OPERATION	
Clutch Control Lever	3
Tow Pole Assembly	3
Safety Chains	3
4. MIXER TRANSPORT	4
5. MIXER OPERATION	
Operating the Mixer	4
Starting the Mixer	4
Extension Cords for Electric Motors	4
Loading the Mixer	4
Discharging the Mixer	4
Cleaning	4
Trouble Shooting Guide for MP Mixers	4
6. OPERATING GUIDELINES	
Masonry Construction Guidelines	4
7. LUBRICATION	
Drum Seal Housings	5
Mixing Shaft Bearings	5
Wheel Bearings	5
Drum Shaft Bearing Hangers	5
Engine/Motor	5
8. ADJUSTMENT	
Rubber Wiper Blades	6
Engine/Motor Drive	6
9. STORAGE	6
10. PARTS LISTS AND POWER OPTIONS	
Drum and Drive	8
Mixing Blades	10
Engine Housing Assembly	12
Frame Drive and Clutch Control	14
Engine and Power Options	16-18

1 – SAFETY PRECAUTIONS

THE FOLLOWING PRECAUTIONS ARE SUGGESTED TO HELP PREVENT ACCIDENTS. A CAREFUL OPERATOR IS THE BEST OPERATOR. MOST ACCIDENTS CAN BE AVOIDED BY OBSERVING CERTAIN PRECAUTIONS. READ AND PRACTICE THE FOLLOWING PRECAUTIONS BEFORE OPERATING THIS EQUIPMENT TO HELP PREVENT ACCIDENTS. EQUIPMENT SHOULD BE OPERATED ONLY BY THOSE WHO ARE RESPONSIBLE AND HAVE BEEN PROPERLY INSTRUCTED.

Read all operating and maintenance instruction before operating or servicing the mixer. Test run the empty unit prior to actual use.

A mixer is only as safe as its operator. Give complete and undivided attention to the operations of the mixer.

Know how to stop the mixer and engine/motor instantly in emergency situations.

Ensure that all guards, safety devices, and labels are in place before operating mixer. Close engine housing during mixer operation.

Keep inexperienced and unauthorized people away from the mixer at all times.

Never leave the mixer unattended when it is running

Shut off engine or disconnect electric power before making repairs or adjustments. **NEVER REACH INTO DRUM OR PLACE TOOLS INTO THE DRUM WHILE THE MIXER IS RUNNING.**

Do not overfill- -do not attempt to exceed the mixer's rated capacity.

Do not refuel the engine when it is hot or running.

Do not smoke while refueling the engine.

Block mixer wheels when in operation.

Frequent checks for loose or missing hardware, and regular maintenance will keep the unit in good operating condition.

Avoid loose clothing that could get caught in moving parts or on control levers. **KEEP HANDS AND FEET AWAY FROM MOVING PARTS.**

Never charge or fill the unit prior to starting the mixing blades as an overload encountered in starting a loaded unit could damage the engine/motor or drive components.

Connect safety chains only as instructed as noted in section 3 of this manual when towing the mixer. Connect only to a hitch, or pintle type coupler.

Keep warning, caution and safety instruction labels clean and in good condition. Replace missing, damaged or illegible labels.

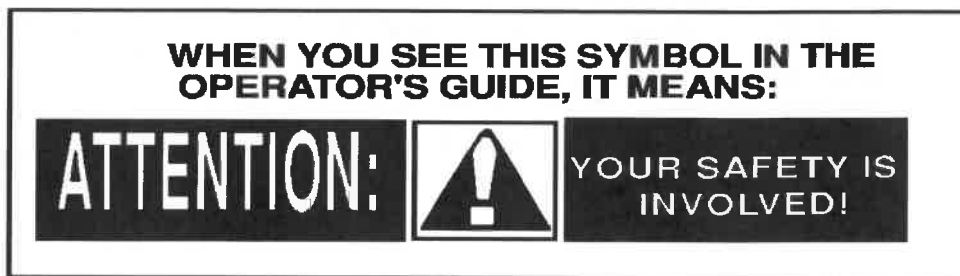

2 – ASSEMBLY AND PRO-OPERATIONAL CHECKS

The only assembly required on this mixer is the installation of the drum tilt handle. Remove the handle from the bag shipped in the drum and install, referring to parts list Figure 5.

The following steps should be taken prior to placing the mixer in use:

1. The operator must be familiar with the location and operation of all controls.
2. Check the crankcase oil level on gasoline powered units, and fill the fuel tank before attempting to start.
3. Check for free rotation of the paddles and mixer shaft. Rotate the drum through one complete dump-charge-dump cycle. Ensure that no foreign objects or tools are in the drum before starting engine/motor.
4. Start engine/motor, engage drive and check for smooth operation of paddle arms, shaft, and drive components.
5. Engage and disengage clutch several times to ensure proper operation.

3 – CONTROLS AND OPERATIONS

DRUM LATCH

Lift the drum latch to rotate the drum into the dump position. The latch should automatically engage when the drum is returned to the mix/transport position. (SEE FIGURE 3)

CLUTCH CONTROL LEVER



WARNING: To avoid personal injury, this control must be disengaged before starting engine/motor or when mixer is not in use.

This control is located at the front mixer leg. This control engages and disengages power to the paddle shaft. SEE FIGURE 1.

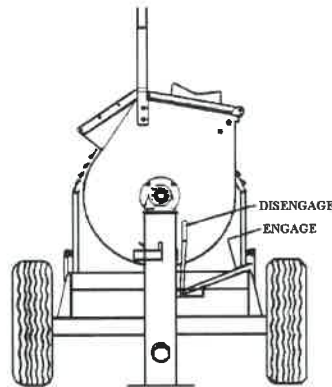

FIG. 1

ENGAGE PADDLE DRIVE: Place lever in 2:00 position.

DISENGAGE PADDLE DRIVE: Place lever in 12:00 position.

ENGINE/MOTOR CONTROLS

Electric powered units have an motor start switch and emergency stop mounted in an electrical enclosure. A three wire outdoor power cord is pre-wired into the switch. When connecting the power cord, always connect to mixer first, and then connect to a grounded receptacle. When disconnecting the power cord, always turn mixer off first.

Refer to the engine operating instructions for gasoline powered units.

TOW POLE ASSEMBLY

The tow pole assembly is located on the front of the mixer and is used for transport only. The mixer is shipped with the tow pole in the stowed position (retracted). Use this position when operating the unit. For transport, extend the tow pole and secure with the “L” shaped pin provided.

SAFTEY CHAINS



WARNING: To avoid personal injury, safety chains must be properly utilized whenever the mixer is towed.

When transporting the mixer ensure that:

1. The drum is in the mix position and that the drum latch is securely engaged.
2. The engine housing latches are engaged.
3. The tow pole is extended and secured with “L” pin.
4. The safety chains cross under the tow pole to support the mixer if disconnected from tow vehicle. (SEE FIGURE 2)
- 5. The chains pass around a frame member or other secure point and the end hooks are attached back to a chain link. Do Not attach the end hooks directly to a bumper hole or frame member – they can not support their designed load rating when used in this manner.**
- 6. Only enough slack to permit an unrestricted turn range exists. Do not allow chains to drag or be drawn too tight.**

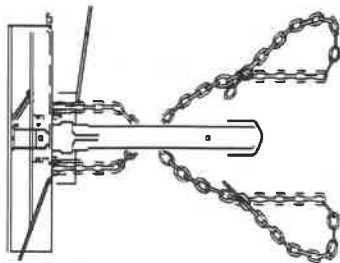

Fig. 2

4 – MIXER OPERATION



WARNING: TO AVOID PERSONAL INJURY, VERIFY THAT THE DRUM IS LOCKED IN THE OPERATING POSITION

1. Place the drum in the mixing position and verify that the drum latch is engaged. (See Figure 3)
2. Visually check the drum for foreign objects or tools.



WARNING: TO AVOID PERSONAL INJURY, THE GRILL ASSEMBLY MUST BE DOWN AND IN PLACE DURING MIXER OPERATION.

3. Close grill assembly.



WARNING: TO AVOID PERSONAL INJURY, THE CLUTCH LEVER MUST BE IN THE DISENGAGED POSITION BEFORE STARTING ENGINE/MOTOR.

4. Place clutch lever in the disengaged position (See Figure 1).
5. Start the mixer engine/motor (refer to the engine/motor manual for proper starting Procedures).
6. When the engine/motor is running smoothly, engage the clutch lever – the paddle shaft assembly should rotate smoothly and freely – the desired mixing speed is 33 RPM
7. While the mixing blades are rotating, pour the required amount of water into the drum. Then add cement, sand, and the lime as required. **Do Not exceed the rated capacity of the mixer.**

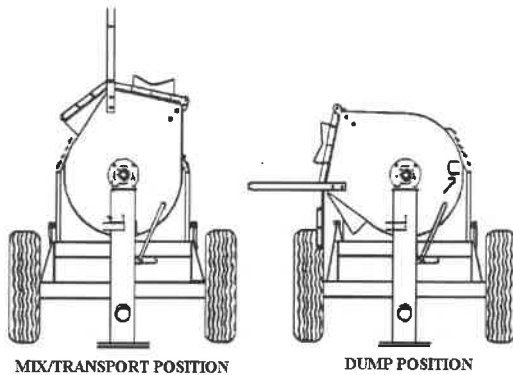

FIG. 3

8. Allow the entire mixture to mix for one (1) full minute. **DO NOT DISENGAGE DRIVE CLUTCH LEVER.** Release drum latch and rotate the drum to the dump position while the paddles continue to rotate. After the mixture is discharged, return the drum to the operating position and verify engagement of drum latch.

EXTENSION CORDS FOR ELECTRIC MOTORS

Extension cord must be a 3-wire power plug – approved for outdoor use. When connecting the power cord, always connect to mixer first and then plug into a grounded receptacle. When disconnecting the power cord, always turn mixer off first.

The following wire gauges are recommended for the lengths listed:

Up to 100 ft.-14 gauge wire w/ground

Up to 200 feet-12 gauge wire w/ground

Up to 300 feet-10 gauge wire w/ground

Up to 400 feet-8 gauge wire w/ground

Always use a power source with a ground fault interrupter circuit.

CLEANING

⇒ To achieve satisfactory performance from the mixer, it is essential to give the unit reasonable care.

⇒ Clean the mixer after each use, *before* the mortar dries and becomes hard. Never allow mortar to harden on either the inside or outside of the drum.

⇒ Do not attempt to remove hardened mortar by pounding on the drum with objects. Dents in the drum will cause accelerated wear spots and impair mixing efficiency. Wash down the entire unit after each day.

⇒ There are several release agents available that will make clean up easier. Contact your dealer for information on Crete Clean™.

6 – LUBRICATION

1



WARNING: To avoid personal injury, always turn off engine/motor and wait for all motion to stop before cleaning, making adjustment or repairs.

DRUM SEAL HOUSINGS

Drum seal housings are attached to each end of the drum. Each has a grease fitting located at the top, and a vent port on the bottom. It is important to grease this component weekly, more often during heavy use to retain seal efficiency. Use a lithium based grade 2 multi-purpose grease

DRUM SHAFT BEARING HANGERS

The drum bearing hangers support the drum assembly and provide the pivot point for drum rotation. These bearings should be lubricated weekly with a lithium based grade 2 multi-purpose grease.

MIXING SHAFT BEARINGS

The mixing shaft bearings are permanently factory sealed and lubricated, No further service is required.

WHEEL BEARINGS

Wheel bearings should be disassembled, cleaned, and repacked annually. Use #2 wheel bearing grease or equivalent.

PINION SHAFT BEARINGS

Pillow block style bearings are utilized on the drive train pinion shaft. These bearings should be lubricated after every 100 hours of operation. More frequently during heavy use. Use a lithium based grade 2 multi-purpose grease.

IDLER PULLEY

The idler pulley contains a factory sealed and lubricated bearing. No further service is required.

ENGINE/MOTOR

Refer to the engine/motor operating instructions for all maintenance, lubrication and specifications.

7 – ADJUSTMENT



WARNING: To avoid personal injury, always turn off engine/motor and wait for all motion to stop before cleaning, making adjustment or repairs.

MIXING PADDLES

1. The mixing paddles feature adjustable rubber wipers and steel backing plates. These items are factory preset for appropriate drum clearance. If adjustment is required, proceed as follows:
 - a. loosen wiper hardware and position blade so that even contact is achieved without folding the wiper over when in operation.
 - b. After adjustment, rotate the paddle shaft one full revolution to manually verify clearances before engaging power. Verify that the steel backing plates DO NOT contact the drum.
2. Read through the manual for all operation, adjustment, and maintenance instructions.
3. Check all hardware after the first two (2) hours of operation, recheck prior to each operation.

IDLER/TENSIONER



WARNING: To avoid personal injury, always turn off engine/motor and wait for all motion to stop before cleaning, making adjustment or repairs.

Belt tension is preset at the factory, after approximately 40 hours of operation an adjustment may be necessary to compensate for normal belt stretch. This may be accomplished by adjusting the linkage rod connected to the idler/tensioner pulley bracket.

IMPORTANT: Do Not over tension the belts, doing so will prevent the clutch from disengaging power to the paddle shaft. Maintain enough free play in the belts so that they will slip when the clutch is disengaged.

Periodically check the alignment of all pulleys and gears for proper operation.

There are two belt fingers (upper & lower), the upper is attached to the engine and should be positioned so that minimum contact exists with the belts near the pinion pulley. The lower belt finger is attached to the idler pulley, adjust with the idler pulley in the engaged position, rotate the lower finger so that it makes contact with the main frame tube. Re-tighten the idler pulley bolt and move the idler pulley to the disengaged position, the finger should make contact with the belts and provide slack to the drive pulley so that it may rotate freely. Ref. Figure 4.

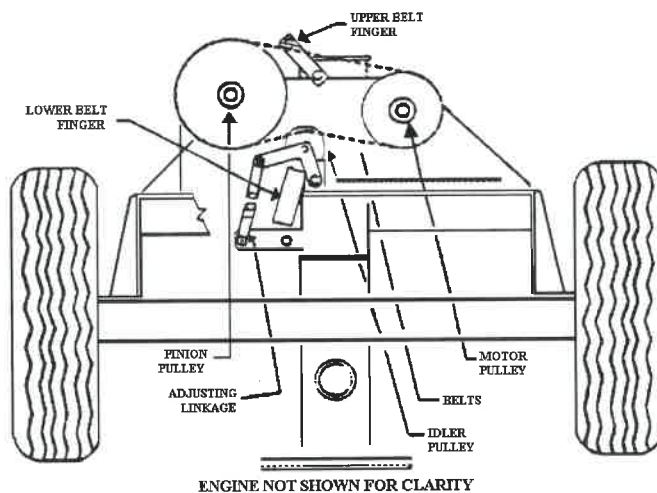

FIG. 4

8 – STORAGE

For short term storage, clean the mixer and store in a dry location.

For long term storage prepare the mixer as follows:

1. Clean the unit thoroughly.
2. Lubricate per instructions outlined in the LUBRICATION section.
3. Refer to the engine/motor instructions for storage instructions.
4. Cover exposed metal surfaces with a thin coat of SAE 30 weight engine oil.
5. Store in a dry location.

9 – OPERATING GUIDELINES

MASONRY CONSTRUCTION GUIDELINES

The strength and durability of brick masonry depends upon the quality of the brick, the quality of the mortar and the workmanship in laying. The strength also depends upon adequate bond and the shape of the masonry unit.

Brick quality – Characteristics are hardness and density. Brick for masonry which is exposed to weather or where strength is desired should have a crushing strength of not less than 2500 PSI.

Laying and bonding – Brick should be laid in a full bed of mortar and shoved laterally into place to secure solid bearing, a bed of even thickness, and to fill the vertical joints. Brick should be thoroughly wet before laying, except in freezing weather. Bricks laid with the long dimension parallel to the face of the work are called stretches, perpendicular to the face are called headers. Bats (chalk bricks) should not be used except where necessary to make corners or to form patterns on the face of the walls. Walls are bonded or tied together longitudinally by overlapping stretches in successive courses. Transverse bond is obtained by making every sixth course headers with the headers themselves overlapping in successive courses in the interior of thick walls.

Mortars – Mortar composition is dependent on the structural use of the masonry unit. It is also dependent upon grade, weather exposure and climactic condition. Consult your brick or block supplier, the ACI (*American Concrete Institute*) Manual of Concrete Practices or your local building codes for the proper mortar selection for each application form more information.

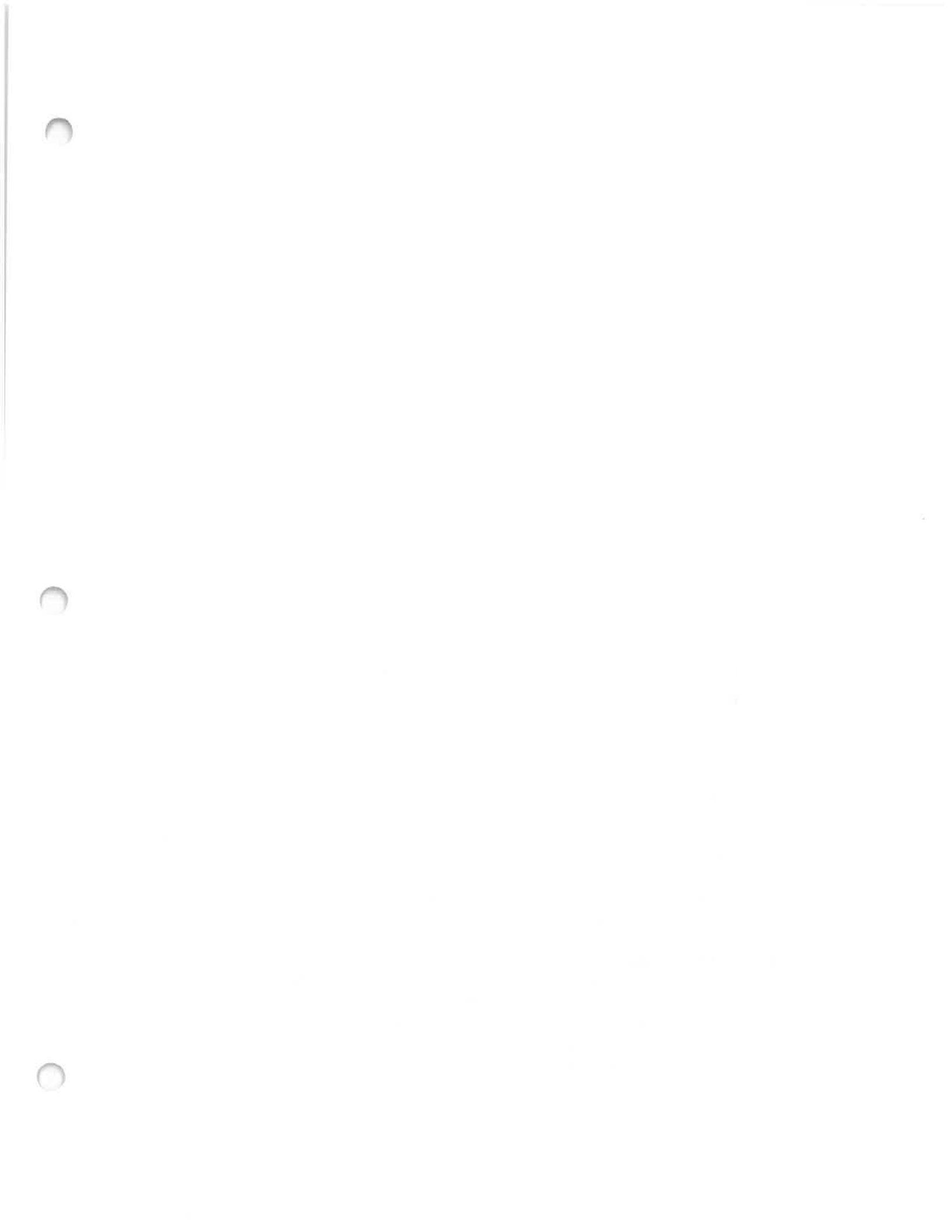

GILSON MIXER WARRANTY

WARRANTY:

This mixer is warranted to the original purchaser only, to be free of defects in material and workmanship under normal use, for one year from purchase date. Cleform Tool Corp. shall without charge, repair or replace parts which are found to be defective. All transportation charges for replacement parts must be borne to the purchaser.

For warranty service, the product must be delivered, with proof of purchase date, to the dealer of original purchase, or any factory authorized service dealer. The delivery of the unit must be made no later than 30 days after the expiration of the warranty period.

If difficulty is encountered in having the warranty work performed, contract the factory Service Department directly.

EXCLUSION FROM THIS WARRANTY:

1. The following items are not covered under the CLEFORM TOOL CORP. One Year Limited Warranty and are warranted by the respective manufacturer.
 - a) Engines, including starters, generators, alternators and gear reducers.
 - b) Enclosed gear transmissions.
 - c) Hydraulic components, including pumps, motors and valves

- d) A copy of the warranty and service contract information for the above items is furnished with the individual product.
2. All consequential damages, including pickup and delivery of the unit, communication, mileage charges and/or rental of a replacement unit during repairs are not covered under this warranty, nor is any loss of income and/or other loss resulting from the failure of the product to function due to a warranty defect.
 3. This warranty will not apply when the product becomes inoperative due to misuse, normal wear, neglect, improper maintenance, accident or freight damage; has not been operated and maintained in accordance with the instructions furnished in the Operator's Manual; or has been altered or modified without approval from the factory Service Department.
 4. No parts or products are to be returned to the factory without prior written approval from the factory.

ALL IMPLIED WARRANTIES, INCLUDING THOSE OF MERCHANTABILITY AND FITNESS FOR A PARTICULAR PURPOSE, ARE LIMITED TO ONE YEAR FROM DATE OF PURCHASE BY THE ORIGINAL RETAIL CUSTOMER AND TO THE EXTENT PERMITTED BY LAW ANY AND ALL IMPLIED WARRANTIES ARE EXCLUDED AND DISCLAIMED AFTER THE EXPIRATION OF SUCH PERIOD.

Some states do not allow limitations on how long an implied warranty lasts, or the exclusion or limitations of incidental or consequential damages, so the above limitations or exclusions may not apply to you.

This warranty gives you specific legal rights, and you may also have other rights, which vary from state to state.

HOW TO OBTAIN PARTS AND SERVICE INFORMATION

For parts and service information, contact either
your local dealer or the Cleform Tool Corp. factory:

CLEFORM TOOL CORP.
4343 EASTON ROAD
ST. JOSEPH, MO 64503
800-253-3676 PHONE
888-253-3676 FAX

HOW TO ORDER PARTS

When ordering parts be sure to indicate the
following information:

- **Name of each part**
- **Complete part number**
- **Quantity of each part**
- **Model Name** (Include all letters and numbers)
- **Serial Number** (Include all letters and numbers)