

BULLET

BY MARSHALLTOWN®

SHARPSHOOTER 2.0

Part# ES00-2009 | EDI# 29977



104 S. 8th Ave. | Marshalltown, IA
Phone 800-888-0127 / 641-753-0127 | Fax 800-477-6341 / 641-753-6341
www.MARSHALLTOWN.com
WS2543

INTRODUCTION

Thank you for your purchase of the Bullet by MARSHALLTOWN SharpShooter 2.0. This versatile, light-duty flooring and siding cutter is proudly Made in the USA, manufactured with the highest-grade materials, and designed with the flooring and siding professional in mind.

Your new SharpShooter 2.0 includes features such as:

- Easy and quiet one-cut action
- A longer handle for added leverage and cutting power
- Ability to cut inside without dust, noise, or electrical cords
- Built-in ruler for accurate cuts
- Full table with high-density polymer wear surface

And can cut materials up to $\frac{9}{16}$ " thick and 9" wide, including:

- LVP/LVT/WPC/MLF/SPC
- Engineered hardwood flooring (solid up to $\frac{3}{8}$ " thick and 1250 Janka)
- Laminate flooring (up to 10 mm thick)
- PVC tile
- Rubber tile
- Cove base
- Pressboard lap
- Shingles (tar or wood up to 9" wide)
- Vinyl siding (up to 9" wide or double $3\frac{1}{2}$ ")
- Fiber cement siding

This owner's manual provides the information needed to operate and maintain this SharpShooter 2.0. Carefully read and follow all safety and operating instructions in this manual. Ensure every operator of this flooring shear reads this manual before operating the unit. The replacement of any part on this flooring shear by other than the manufacturer's authorized replacement part may adversely affect the performance, durability, or safety of the product.

Be sure safety precautions are observed. Read and follow all safety and operating instructions in this operator's manual. The manufacturer reserves the right to make changes on or add improvements to its product at any time without prior notice or obligation. The manufacturer reserves the right to decide, upon its sole discretion and at any time, to discontinue this product.

This manual covers the SharpShooter 2.0. For technical questions or repair parts, please call MARSHALLTOWN customer service at 1-800-888-0127 or visit www.MARSHALLTOWN.com.

TABLE OF CONTENTS

Introduction.....	2
Safety Precautions.....	3
Safety Decals	4
Warranty.....	5
Product Operation	7
Cutting Guide	9
Maintenance	11
Parts Breakdown	15
Troubleshooting.....	19

SAFETY PRECAUTIONS



- DANGER or WARNING safety signs are located near specific hazards.
- General precautions are listed on CAUTION safety signs.

- This notation appears before warnings in the text. It means that the step that follows must be carried out to avoid the possibility of personal injury or death. These warnings are intended to help the technician avoid any potential hazards encountered in the normal service procedures. We strongly recommend that the reader takes advantage of the information provided to prevent personal injury or injury to others.

THE FOLLOWING PRECAUTIONS ARE SUGGESTED TO HELP PREVENT ACCIDENTS. A CAREFUL OPERATOR IS THE BEST OPERATOR. MOST ACCIDENTS CAN BE AVOIDED BY OBSERVING CERTAIN PRECAUTIONS. READ AND TAKE THE FOLLOWING PRECAUTIONS BEFORE OPERATING THIS EQUIPMENT TO HELP PREVENT ACCIDENTS. EQUIPMENT SHOULD BE OPERATED ONLY BY THOSE WHO ARE RESPONSIBLE AND INSTRUCTED TO DO SO.



CALIFORNIA PROPOSITION 65 WARNING: This product can expose you to chemicals known to the State of California to cause cancer, birth defects, or other reproductive harm.

- Read all operating and maintenance instructions before operating or servicing the flooring shear.
- A flooring shear is only as safe as its operator. Give complete and undivided attention to the operation of the flooring shear.
- Know how to stop the flooring shear instantly.



NEVER operate the flooring shear if any shear components have been removed.

- Keep inexperienced and unauthorized people away from the flooring shear at all times.
- Keep the flooring shear in good operational condition. Loose or damaged parts are dangerous.
- Avoid loose clothing that could get caught in moving parts.



Keep hands and feet away from moving parts.

- Keep all warning, caution and safety instruction labels in good condition. Replace missing, damaged or illegible labels.
- Clear the work area around the shear to prevent tripping or falling onto the shear.
- Operate on level ground to prevent the flooring shear from flipping over.
- DO NOT OPERATE this flooring shear under the influence of alcohol or while taking medication that impairs your reactions.
- Use only factory authorized parts for replacement.
- Wear safety glasses when operating the flooring shear.
- Always use caution when replacing the shear blade.
- Only operate the shear with the approved materials. If extreme force is required to cut a material, it may result in personal injury and/or damage to the flooring shear.
- Wear proper protective clothing while operating flooring shear, including eye, ear, and clothing.
- Handle all solvents and cleaning agents with care and follow manufacturer's instructions on safety and disposal.

SAFETY DECALS

If your safety decals are damaged, they can be replaced by contacting Customer Service.

Blade Warning Label



Handle Warning Label



WARRANTY

This product is warranted to the original purchaser only, to be free of defects in material and workmanship under normal use, for one year from purchase date. MARSHALLTOWN shall without charge for parts and labor, repair or replace such parts which are found to be defective. All transportation charges for replacement parts must be borne by the purchaser.

For warranty service, the product must be delivered, with proof of purchase date, to MARSHALLTOWN. Contact MARSHALLTOWN Customer Service to determine the best method of delivering the product that is under warranty. The delivery of the product must be made no later than 30 days after the expiration of the warranty period.

All implied warranties, including those of merchantability and fitness for a particular purpose, are limited to one year from date of purchase by the original retail customer and to the extent permitted by law any and all implied warranties are excluded and disclaimed after the expiration of such period.

Some states do not allow limitations on how long an implied warranty lasts, or the exclusion or limitations of incidental or consequential damages, so the above limitations or exclusions may not apply to you. This warranty gives you specific legal rights, and you may also have other rights, which vary from state to state.

Exclusion from this warranty:

1. All consequential damages, including pickup and delivery of the unit, communication, mileage charges and/or rental of a replacement unit during repairs are not covered under this warranty, or are any loss of income and/or other loss resulting from the failure of the product to function due to a warranty defect.
2. This warranty will not apply when the product becomes inoperative due to misuse, normal wear, neglect, improper maintenance, accident or freight damage; has not been operated and maintained in accordance with the instructions furnished in the Operator's Manual; or has been altered or modified without approval from the factory Service Department.
3. No parts or products are to be returned to the factory without prior written approval from the factory.

PRODUCT OPERATION

When most materials are cut, the 'drop' piece will have a beveled edge, while the 'keep' piece (the piece left on the table) will have a mostly square edge.

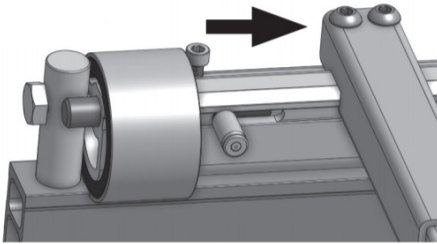

1. Slide the Camlock lever over to unlock shear.

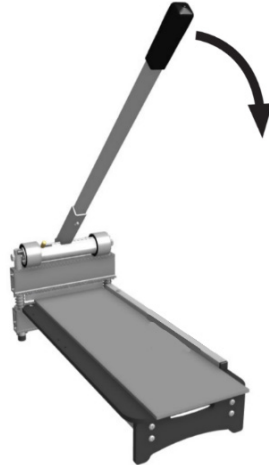

2. Place product on table. It is recommended that you **HOLD MATERIAL IN PLACE** until the cut is complete. Bring handle down until blade touches material.

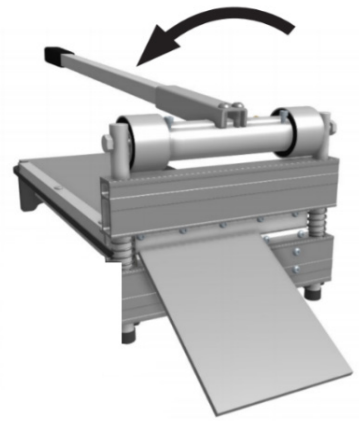

3. Push handle down until the material is cut completely. Some effort may be required depending of hardness of material.

SAFETY LOCK

The safety lock can be disengaged by sliding the knob over.

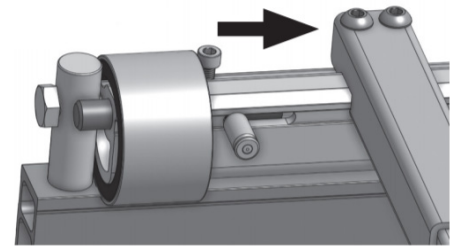

TRANSPORT

Always re-engage the Safety Lock pin and secure the extended handle in the down position while storing, carrying, or transporting your shear.

CUTTING GUIDE

The SharpShooter 2.0 is designed to cut a variety of materials. Some of the most common materials are LVP/LVT/WPC/MLF/SPC, engineered hardwood flooring (solid up to $\frac{3}{8}$ " thick and 1250 Janka), laminate flooring (up to 10 mm thick), PVC tile, rubber tile, cove base, pressboard lap, shingles (tar or wood up to 9" wide), vinyl siding (up to 9" wide or double 3½"), and fiber cement siding.

Note: DO NOT attempt to cut any solid wood, high pressure laminate, or engineered hardwood with a Janka Hardness Rating higher than 1250.

Note: Even the approved materials may vary greatly in density and hardness. If extreme force is required to cut a material stop immediately, as it could lead to damage to your shear or injury. Attempting to cut unapproved materials will void the warranty.

45 DEGREE CUTS

Firmly lift the friction-fit fence to remove it from the table and press back down in the appropriate 45-degree position.

NOTE: This image is for the Marksman. Your shear may look slightly different.

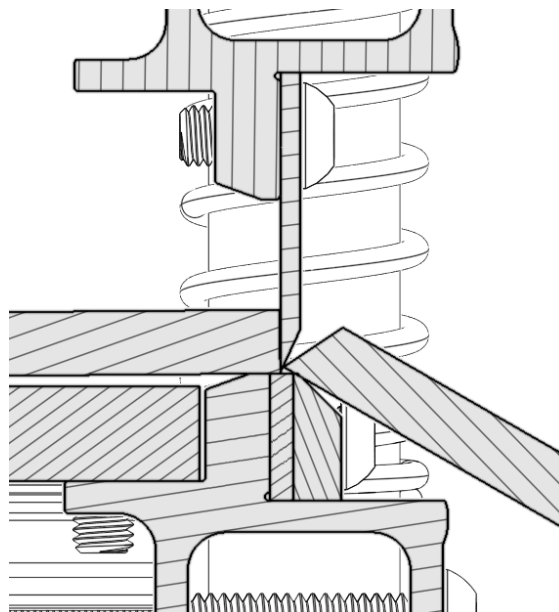
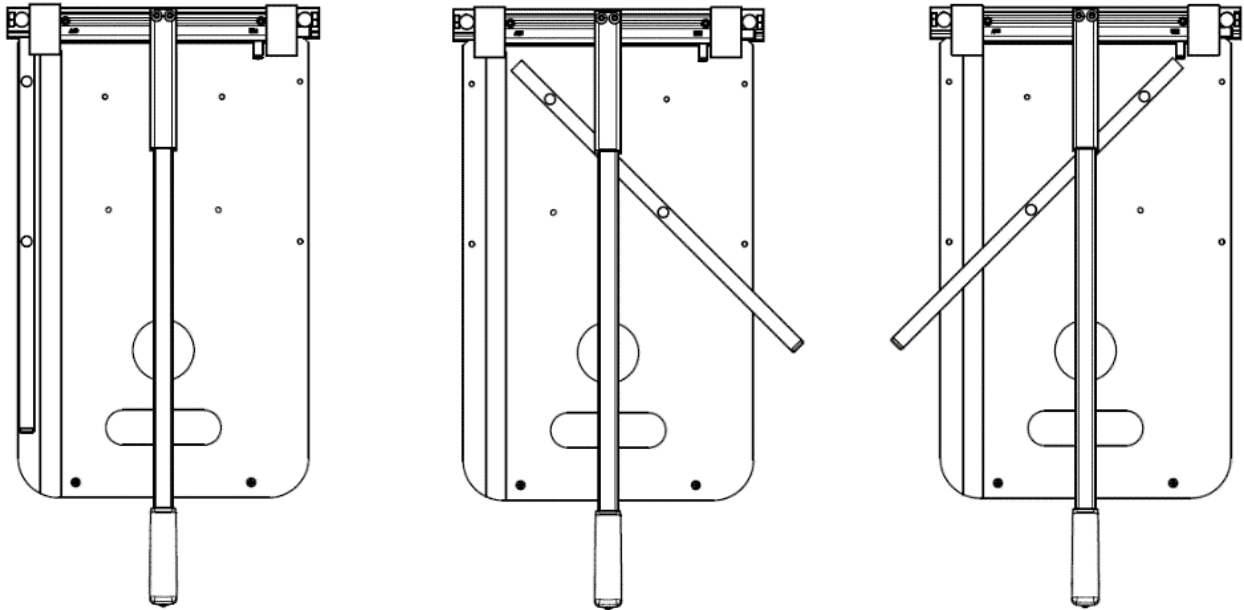

DOUBLE CUTTING

Most materials shear very well with just one cut. However, some brands of fiber cement siding and other products may require cutting twice to produce a better cut. Simply make your first cut $\frac{1}{8}$ " to $\frac{1}{4}$ " (3 to 6mm) longer than your mark, then go back and make your second cut on your mark. This is very useful to create a cleaner cut when a trim molding or transition cannot be used to cover your cut end.

MAINTENANCE

Honing the Blade

Push the handle down until the blade $\frac{1}{8}$ " (3mm) above the tabletop. Place the provided Hone Stone against the flat side of the blade. Slide the honing stone from one end of the blade to the other 3-4 times. This will remove any burrs from your blade.

When you first get your shear, you should hone after your 5th cut, then hone your blade every 10th cut for the first 100 cuts until your blade is broken in. From there, you only need to hone once per job. Use caution when honing the blade. The blade is sharp and can easily cause injury. Cut-resistant gloves are recommended when honing the blade.

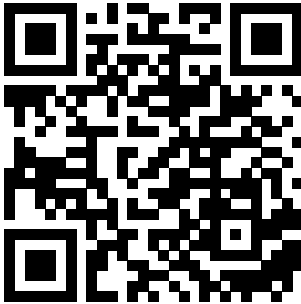

For more information on honing your blade, scan the QR code or visit www.marshalltown.com/honing-your-blade

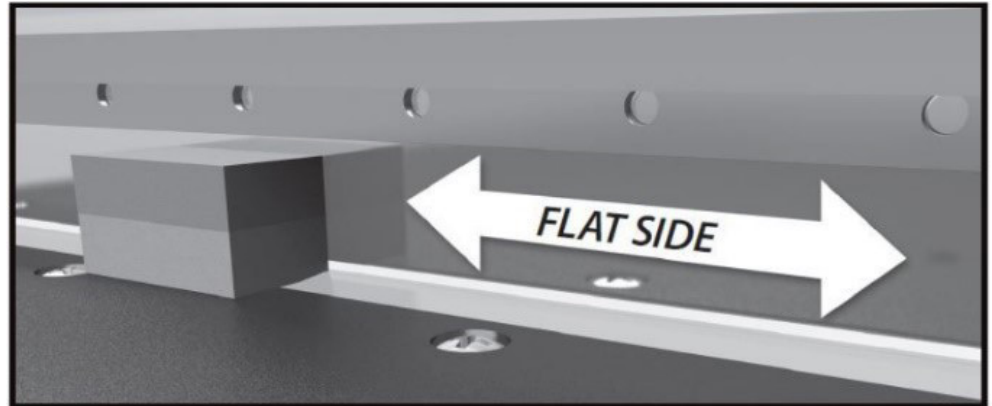

Sharpening the Blade

The blade can be sharpened to restore a one-sided, 21° – 22° knife edge. It is important to note that the blade must be sharpened only on the beveled side, leaving the flat side flat. We recommend that power grinding only be done professionally, as the blade must be fluid cooled during this process.



Replacing the Blade

WARNING: Blade is extremely sharp! Use cut-resistant gloves when replacing the blade.

- 1. TURN SHEAR UPSIDE DOWN** Tip: put the shear on the edge of a sturdy table.
- 2. LOOSEN BLADE** Using a Phillips screwdriver, remove the screws.
- 3. REMOVE BLADE** Hold blade by each end and carefully lift out of pocket.
- 4. INSTALL BLADE** Hold blade by each end and carefully place into the blade pocket in the head, with the flat side of the blade facing the table. Be sure that it is firmly seated, and the pocket is clear of debris.
- 5. TIGHTEN THE BLADE** Using a Phillips screwdriver, replace & tighten the screws, starting with the center screw.

NOTE: This image is for the SharpShooter 2.0. Your shear may look slightly different.

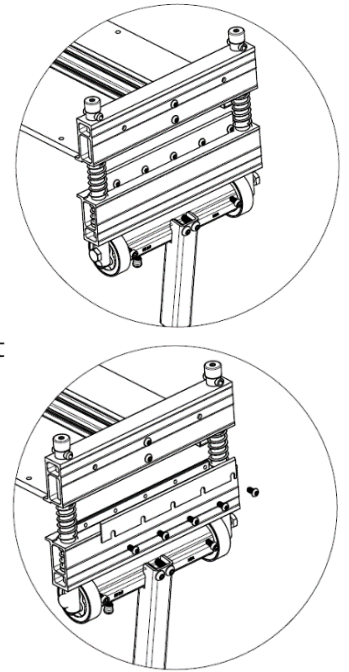

Lubrication

After every 100 cuts, it is recommended that the shear be lubricated. Use a light oil and grease (wheel bearing grease) and apply according to the image below. Lubricating the shear will extend the life of the shear and result in easier cutting.

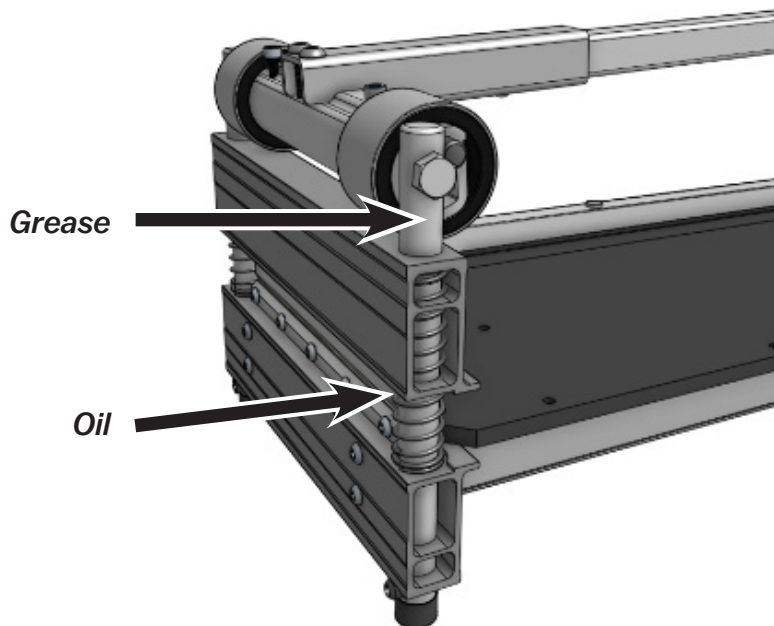

PARTS BREAKDOWN

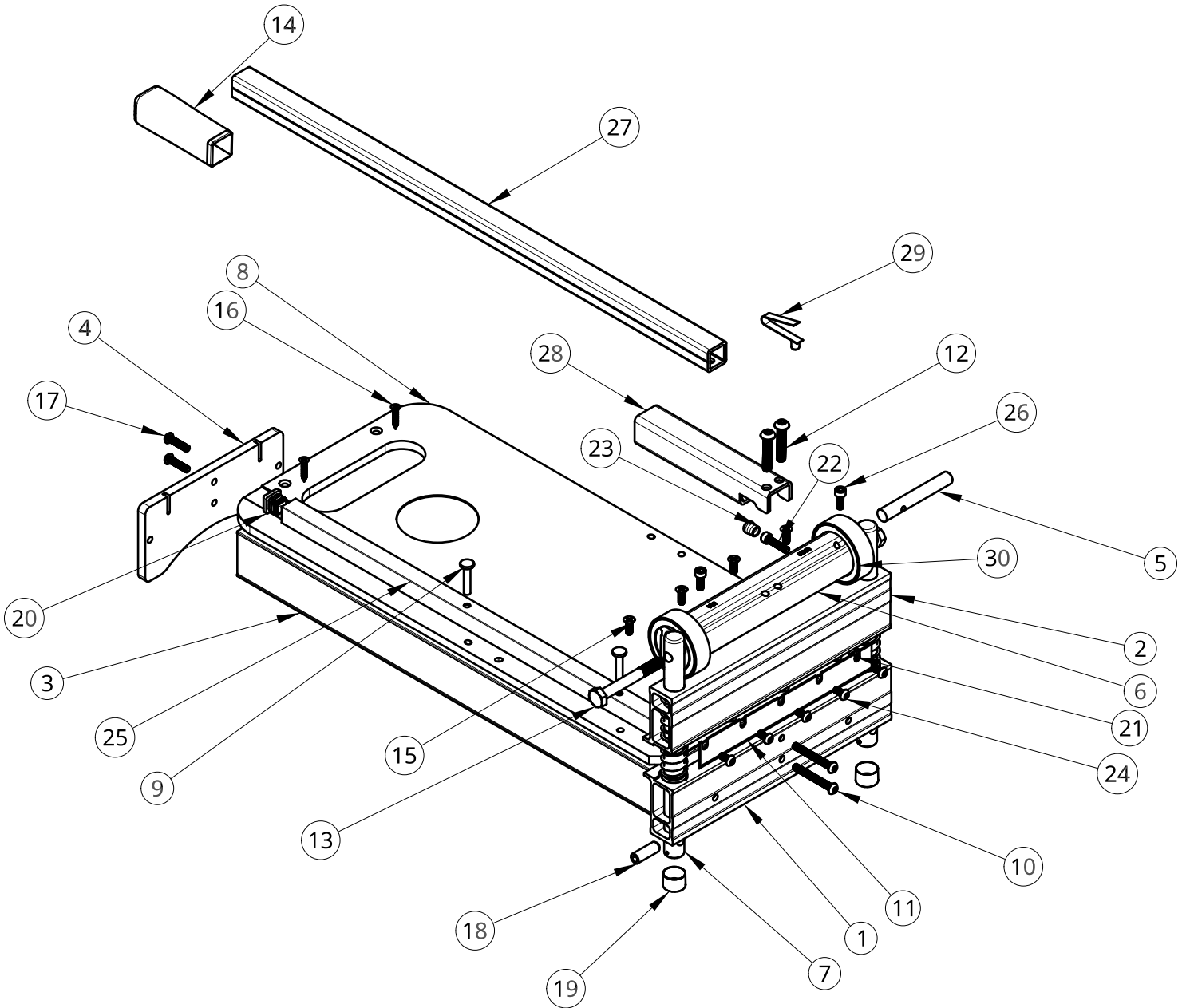

PARTS BREAKDOWN

REF #	DESCRIPTION	EDI	PART#	QTY
1	SHARPSHOOTER 2.0 BASE	R7090	CON-BSE-2009	1
2	SHARPSHOOTER 2.0 HEAD	R7217	CON-HED-2009	1
3	22 ³ / ₈ x 2 SHEAR RAIL, 0.95" C2C	R7270	CON-RAL-W022	1
4	SHARPSHOOTER 2.0 TAIL	R7313	CON-TAL-2009	1
5	1/2" DIAMETER CAM LOCK PIN	R7154	CON-CML-D900	1
6	SHARPSHOOTER 2.0 CAMSHAFT	R7128	CON-CAM-2009	1
7	SHARPSHOOTER LITE PIN	WU915	COT-PIN-0400	2
8	SHARPSHOOTER 2.0 TABLE IDENTICAL TO SHARPSHOOTER PRO TABLE	R7334	CON-TBL-2009	1
9	1/4 X 1 1/4" FLAT HEAD AL RIVET	WR1553	FAS-RVT-2513	2
10	1/4-20 x 2" BHSCS ZINC PLT	WR1584	FAS-SCW-5420	2
11	009 BLADE .062 THK 1095/SK-5	WX2578	RAW-BDE-009B	1
12	M8-1 1/4 x 40 BHSCS ZINC PLT	WR1589	FAS-SCW-5840	2
13	BOLT, M10 x 80 HEX, 10.9, ZINC PLT	WR1510	FAS-BLT-EZ80	2
14	GRIP, 1" x 4", SQ TEXTURED RUBBER	WK230	GEN-HAN-0100	1
15	M6-1 x 16 FHPMS ZP	WR1604	FAS-SCW-8569	4
16	#10 x 1 FHPSMS	WR1556	FAS-SCW-0010	2
17	M6-1 x 25 BH TORX MS ZINC PLT	WR1598	FAS-SCW-7625	2
18	PIN, TENSION, M10 x 30	WR1508	FAS-PIN-EZ02	2
19	FOOT CAP, 3/4" BLACK VINYL, FCR-12	WL793	GEN-CAP-5039	2
20	EZ END CAP, BLACK, FITS SQ TUBE ID OF 0.584 - 0.68"	WL790	GEN-CAP-1075	1
21	SPRING, COMPRESSION, 0.989 x 4", x 0.105, 14 COIL	WL1635	GEN-SPR-4075	2
22	M6 x 25 SHCS ZP (Mc#90128A265)	WR1737	FAS-SCW-EZ04	1
23	RED CAP, CAM LOCK - 1.0.343" x 0.500" RED SHORT CAP - 5304/BOX	WL797	GEN-CAP-9375	1
24	M6-1 X 12 BHSCS ZINC PLT	WR1585	FAS-SCW-5612	5
25	RIVETED SHEAR FENCE 19 3/4"	R7178	CON-FNC-1000	1
26	M6-1 X 16, SHCS, ZINC PLT	WR1581	FAS-SCW-5021	2
27	009 UPPER HANDLE	R7204	CON-HAN-U009	1
28	SHARPSHOOTER PRO AND MARKSMAN LOWER HANDLE	R7198	CON-HAN-L100	1
29	BUTTON SPRING, HAIRPIN, 5/16	WR1630	GEN-SPR-0847	1
30	SHARPSHOOTER 2.0 BEARING	R7353	SUB-BNG-2009	2

REPLACEMENT PARTS

REPLACEMENT EDI	REPLACEMENT PART#	DESCRIPTION	INCLUDES DETAIL #'S
29788	109B	REPLACEMENT 9" EZ SHEAR BLADE	11
29772	2009-RP-PH	SHARPSHOOTER 2.0 REPLACEMENT POWERHEAD	2,5,6,7,13,19,23,24,26,30
29898	863-RP-EZ80	M10 X 80 HEX AXLE BOLTS REPLACEMENT SET	13
29906	868-RP-EZ	REPLACEMENT HANDLE GRIP, 1" SQ X 4"	14
29860	847-RP	REPLACEMENT HANDLE SPRING PIN, 5/16" 1 SIDED	29
29881	858-RP-U009	1" SQUARE REPLACEMENT HANDLE UPPER ONLY (SHARPSHOOTER & MARKSMAN)	14,27,29
29870	856-RP-100F	FENCE REPLACEMENT FOR SHARPSHOOTER, MARKSMAN, EZ SHEAR	9,20,25
29855	838-RP-EZ	FOOT CAP REPLACEMENT (2EA) FOR SHARPSHOOTER, MARKSMAN, EZ SHEAR	19

TROUBLESHOOTING

Before troubleshooting double-check the manual:

- Is your shear properly assembled?
- Is it being operated correctly?
- Is it properly lubricated?
- Has the blade been honed as recommended?

Visually inspect shear, watching for objects that might obstruct the blade or powerhead travel:

- Foreign material presence between the blade and anvil, in the pin springs or under the cam.
- Check your blade for chips, cracks or burrs.
- Make sure bearings are intact and lubricated. They should not be spinning/moving on the cam during use.

NOTE: This troubleshooting is for all Bullet shears. If you are uncertain if it pertains to your shear, please contact Marshalltown customer service.

PROBLEM	CHECK FIRST	CHECK SECOND	CHECK THIRD	CHECK FOURTH
Difficulty cutting	Ensure cam lock is OFF. If equipped, engage power lobes (Model 226)	Make sure handle is FULLY extended	Check blade sharpness/condition	Inspect and lubricate bearings/pins
Not cutting completely through material	Inspect pins for oblong/wallowed orifice	Adjust front stroke stop (MAGNUM shears)	Check bearings for wear/play	Ensure blade is proper nominal height
Blade sticking after completing cuts	Check/remove & replace blade stops if damaged	Ensure blade screws are tight	Remove anvil, turn it over, reinstall	Check for marks on anvil (overbite)
Rough or crushed cuts	Check veneer thickness (max= 1/16")	Check blade condition (chips, burrs, breaks)	Ensure blade is honed and sharp	Review approved materials list
Cuts aren't square	Loosen fence screws, align fence, tighten	Check pins for uneven wear	Inspect blade and anvil/blade-stop for contact	
Handle not returning to open position	Ensure pins are lubricated	Apply grease to contact area of bearing	Lubricate axle bolts	Check springs for breakage
Material won't fit into cut area	Check max thickness of material for your shear	Reverse back stroke stop	Ensure blade is proper nominal height	If you have two bearings, switch which bearing is engaged
Cam lock pin bent/stuck	Do not lift or carry shear by the handle	Return handle slowly to open position - do not "let it fly"	Disengage cam lock pin BEFORE cutting	
Blade chipping	Hone as directed in manual (~25 cuts, then daily)	Do not cut stranded bamboo	Do not cut high pressure laminate	Check veneer thickness (max=1/16")
Pin openings wallowed out / oblong where cam axle passes through	Do not lift or carry shear by the handle	Return handle slowly to open position - do not "let it fly"	Check veneer thickness (max= 1/16")	Review approved materials list
Not cutting to edge of material	Check fence alignment - adjust if needed	Do not "angle" material beyond the blade edge	Ensure angle fence(s) are installed with WIDE edge inward (620 model)	

BULLET

B Y M A R S H A L L T O W N®

104 S. 8th Ave., Marshalltown, IA
Phone 800-888-0127 / 641-753-0127
Fax 800-477-6341 / 641-753-6341
www.MARSHALLTOWN.com
WS2543