

GILSON MIXERS

5 1/2 CU. FT.
CONCRETE MIXER
MODEL: 59027

OPERATOR'S GUIDE & PARTS MANUAL

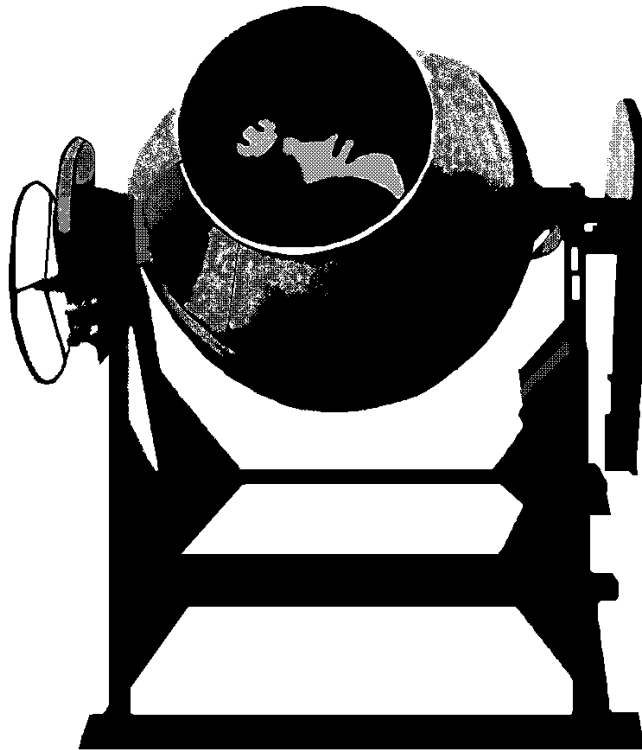

1

GILSON MIXERS
BY



INTRODUCTION

4343 Easton Road · St. Joseph, MO 64503
816-233-4840 · 800-253-3676
Fax 816-233-4624 · 888-253-3676
E-Mail: cleform@ccp.com
Web Address: www.cleform.com

This operator's manual has been prepared to provide the information you need to correctly operate and maintain your unit. Read it carefully and keep it for future reference. Should you ever need repair parts or service, contact your authorized parts and service dealer.

Be sure safety precautions are observed. Read and Follow all safety and operating instructions in this Operator's manual.

The replacement of any part on this product by other than the manufacturer's authorized replacement part may adversely affect the performance, durability or safety of this product.

The manufacturer reserves the right to make changes on, or add improvements to its product at any time without prior notice or obligation. The manufacturer also reserves the right to decide, upon its discretion and at any time, to discontinue a product.

TABLE OF CONTENTS

1. Safety Precautions	2
2. Operation	
Drum Speed	3
Getting Ready For Mixing	3
Loading The Mixer	4
Unloading The Mixer	4
Cleaning The Mixer	4
Extension Cords-Electric Motor	4
3. Lubrication And Storage	5
4. Replacement Decals	
Safety	6
Standard	6
5. Set Up & Assembly	7
6. Concrete Mixer Parts	8
Parts List	9

IMPORTANT: IF SAFETY OR STANDARD Decals are missing, illegible, or damaged, they should be replaced. See "Replacement Decals" section

1-SAFETY PRECAUTIONS

THE FOLLOWING PRECAUTIONS ARE SUGGESTED TO HELP PREVENT ACCIDENTS. A CAREFUL OPERATOR IS THE BEST OPERATOR. MOST ACCIDENTS CAN BE AVOIDED BY OBSERVING CERTAIN PRECAUTIONS. READ AND TAKE THE FOLLOWING PRECAUTIONS BEFORE OPERATING THIS EQUIPMENT TO HELP PREVENT ACCIDENTS. EQUIPMENT SHOULD BE OPERATED ONLY BY THOSE WHO ARE RESPONSIBLE AND INSTRUCTED TO DO SO.

- Read all mixer and electric motor/engine instructions before operation.
- Use a grounded, three wire plug-in for all mixers using an electric motor or an electric starting engine.
- Do not use mixer in standing water if powered by an electric motor or an electric starting engine.
- Do not over-fill the mixer. There should not be any liquid running out of the mixer drum.
- Know how to stop the motor/engine instantly.
- Keep hands and feet away from all moving parts.
- If you are unfamiliar with the mixer, test run the empty mixer prior to actual use.
- Never charge or fill unit prior to starting, as the over-load initially encountered could damage the motor/engine.
- Stop motor/engine whenever you leave or clean the unit. Disconnect power cord on electric motor.
- Never operate mixer without guards being properly positioned and secure.
- Avoid spilling gasoline. Never fill tank while the engine is running or while you are smoking.
- Open doors if engine is running in an enclosed area. Exhaust fumes are dangerous.
- Store gasoline in safe container. Store the container in a cool, dry place. **Do not keep in the house or near heating appliances.**
- Never reach into drum while mixer is running.
- Keep mixer in good operating condition. Loose or damaged parts are dangerous and should be tightened or replaced before operating.
- Keep bystanders, especially children, away from mixer while operating.

2-OPERATION

DRUM SPEED

The mixer drum should revolve between 20 and 25 R.P.M.'s for best results in mixing concrete. To obtain this speed using a 1725/1800 R.P.M. electric motor, use a 2" diameter "A" section V-pulley.

If using a 6 to 1 speed reduction 3 H.P. gasoline engine, use a 6 1/4" diameter "A" section V-pulley.

GETTING READY FOR MIXING

Lay out forms for your concrete floor, patio, driveway, sidewalk, etc.

The quality of concrete is directly related to the quality of the cement paste. The quality of the paste, in turn, is directly related to the amount of water mixed with the cement. For a given amount of cement, as the amount of mixing water is reduced, the strength of the paste increases, making the concrete stronger and more durable.

The proportions by weight given in Table 1 can be used as a starting point to make 1 cu. Ft. (0.028 m³) of strong, durable concrete. The proportions given in Table 2 are volumetric; 1 bag of cement is equal to 1 cu. ft. (0.28 m³) and weighs 94 lbs. (42.6 kg). The Canadian bag of cement has a net mass of 40 kg.

The proportions are only a guide and may need adjustments to give a workable mix with locally available aggregates.

Table 1. Proportions by Weight to Make 1 Cu. Ft. of Concrete

Maximum-size course aggregate in.	Air-entrained concrete				Concrete without air			
	Cement lb	Sand lb	Course aggregate lb	Water lb	Cement lb	Sand lb	Course aggregate lb	Water lb
3/8	29	53	46	10	29	59	46	11
1/2	27	46	55	10	27	53	55	11
3/4	25	42	65	10	25	47	65	10
1	24	39	70	9	24	45	70	10
1 1/2	23	38	75	9	23	43	75	9

*If crushed stone is used, decrease coarse aggregate by 3 lbs and increase sand by 3 lbs.

Metric conversion: 1 lb = 0.121 kg 10 lbs = 4.54 kg
 1 in. = 25mm 1 Cu. Ft. = 0.028 m³

Table 2. Proportions by Volume*

Maximum-size course aggregate in.	Air-entrained concrete				Concrete without air			
	Cement lb	Sand lb	Course aggregate lb	Water lb	Cement lb	Sand lb	Course aggregate lb	Water lb
3/8	1	2 1/4	1 1/2	1/2	1	2 1/2	1 1/2	1/2
1/2	1	2 1/4	2	1/2	1	2 1/2	2	1/2
3/4	1	2 1/4	2 1/2	1/2	1	2 1/2	2 1/2	1/2
1	1	2 1/4	2 3/4	1/2	1	2 1/2	2 3/4	1/2
1 1/2	1	2 1/4	3	1/2	1	2 1/2	3	1/2

*The combined volume is approximately 2/3 of the sum of the original bulk volumes.

LOADING THE MIXER

Start the mixer. Refer to motor/engine instructions. After drum has started rotating, pour about half of the water in the drum..

NOTE: The drum may leak slightly when first used. This will stop after a few batches.

Add aggregate (gravel) first then cement and last sand.

UNLOADING THE MIXER

Refer to Fig. 1

Allow the entire mixture to mix for one full minute. **Do not stop mixer from rotating.** Hold the tilt handle and unlock the stop lever. Dump concrete to either side by tilting the tilt handle in the direction required. Before **reloading** the mixer, slowly pour a pail of water over the lip of the drum, permitting water to clean the inside of drum. When cleaned, dump water. Now you are ready for your next batch.

CLEANING THE MIXER

After each run of concrete has been poured, do the following:

With the drum rotating, spray water into drum permitting the water to run down the inside and outside of drum. Add one shovel full of coarse aggregate and permit this mixture to scour the inside of drum for about two minutes.

This practice will help keep the drum clean, which is essential in obtaining the best mixing result. **Never permit concrete to harden on either the inside or outside of drum.**

EXTENSION CORDS-ELECTRIC MOTOR

The following size extension cords should be used for this mixer: length of cord, up to 100 ft- 14 gauge wire; up to 200 ft-12 gauge wire; up to 300 ft – 10 gauge wire; up to 400 ft – 8 gauge wire.

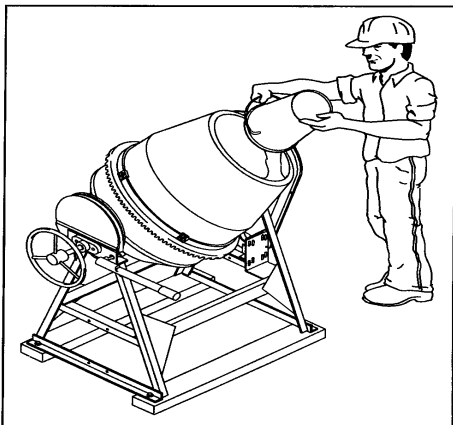

FIG. 1

3-LUBRICATION & STORAGE

Each day before operating, lubricate at the following points:

Engine/Motor – Refer to engine/motor operating instructions for all maintenance and lubrication instructions and requirements.

GREASE FITTINGS:

Refer to Fig. 2

Clean off grease fitting before greasing. Use pressure type grease gun. Grease lightly with general purpose grease (2 to 3 pumps).

- Drum Shaft Bearings (where used)
- Drive shaft Bearings
- Tilt Wheel Shaft Bearings (where used)
- Brake Lever Shaft (where used)

OIL:

Refer to Fig. 2

Use SAE 30 engine oil.

- Yoke Tilt Mechanism

STORAGE

For short term storage, clean the mixer and store in a dry place. If the mixer is not to be used for an extended period of time, service mixer completely and store it in a dry place.

1. Refer to motor/engine instructions for storage instructions.
2. Cover exposed metal surfaces with a thin coat of SAE 30 engine oil.
3. Lubricate per instructions under LUBRICATION & STORAGE section.

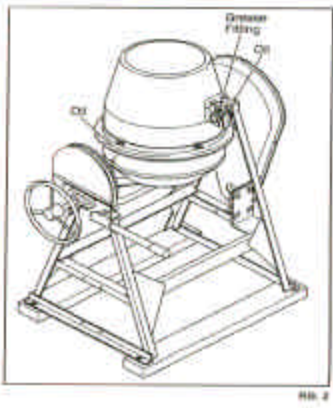

4-REPLACEMENT DECALS

#217728: Decal, Safety Instructions

SAFETY AND OPERATING INSTRUCTIONS

CAUTION!

1. Never reach into drum while it is rotating.
2. Stop engine or motor before cleaning or servicing.
3. Keep children and unauthorized people away from machine.
4. Never allow machine to run unattended.
5. Read owner's manual before operating or servicing this machine.

GENERAL PURPOSE CONCRETE

Proportions by Volume:

- 1 part cement
- 2 1/2 parts sand
- 3 parts aggregate
- 2/3 parts water

With drum rotating, add water, aggregate, cement and sand in that order. Mix will be "mushy" not "soupy" for average moisture sand. Add or delete water if sand is dry or wet.

CLEANING

1. With drum rotating, add water and aggregate.
2. Allow drum to turn for several minutes.
3. Dump water and aggregate.
4. Stop mixer by disconnecting motor or stopping engine.
5. Thoroughly clean with water before cement hardens.

LUBRICATION & SERVICE

1. Lubricate pinion shaft and drum shaft daily when in use.
2. Service engine or motor per manual supplied.

#5706: Decal, Gilson Name Plate



#38257: Decal, Drum Rotation

5-SET-UP AND ASSEMBLY

This mixer is shipped partially disassembled and requires assembling.

1. Remove five ¼-20 x ½hex hd. Cap screws, lock washers and hex nuts that secure cover to the belt guard. Remove cover. (Save all hardware)

INSTALL MOTOR KIT PER INSTRUCTIONS

2. Replace the cover removed in step 1 and secure with hardware (saved). Tighten securely.
3. Bolt the tilt wheel assembly to the tilt pinion. Tighten the set screw securely.
4. Although the mixer was lubricated at the factory, now is the perfect time to become familiar with points requiring regular service. Refer to the LUBRICATION AND STORAGE section.
5. All nuts and cap screws should be checked and tightened during the first two hours of use. Periodic checks should be made thereafter.

59027

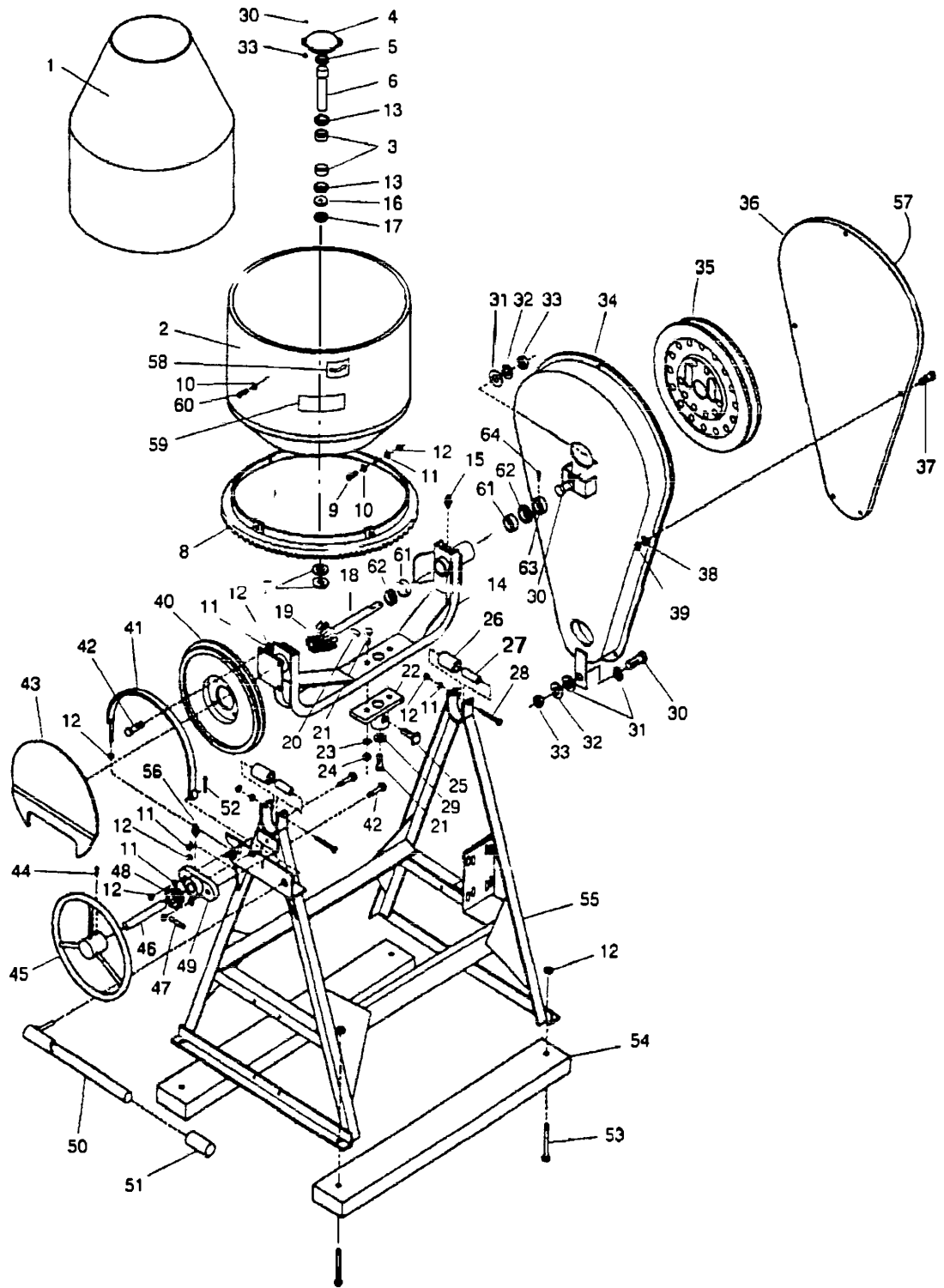

FIGURE 1, 59027 400CM POLY-LINER

Item #	Part No.	Description	Qty
1	771-40257	Poly-liner	1
2	765-40296	Drum Assembly (incl. #3)	1
3	4299	Bearing Cup, Drum (incl with #2)	2
4	5748	Drum Hub Cover	1
5	5749	O-ring	1
6	5003	Drum Shaft	1
7	5042	Drum Shaft Spacer	2
8	5498	Ring Gear	1
9	70249	3/8-16 x 1 1/2 Hex Hd. Cap Screw	5
10	70703	3/8 Flat Washer ZP	7
11	70649	3/8 Lock Washer ZP	14
12	70553	3/8-16 Hex Nut ZP	19
13	4298	Bearing Cone, Drum	2
14	245950	Yoke Assembly (incl. #15 & #61)	1
15	1102	Grease Fitting (incl. with #14)	1
16	5008	Grease Seal	1
17	5009	Spacing Collar	1
18	6008	Drive Shaft	1
19	6007	Pinion Gear	1
20	71017	Roll Pin, 7/32 x 1 1/2	1
21	70343	1/2-13 x 1 1/2 Hex Hd. Cap Screw	3
22	5020	Drum Shaft Bearing	1
23	70655	1/2 Lock Washer ZP	2
24	70563	1/2-13 Hex Nut ZP	2
25	70073	1/2-13 x 1 Square Head Set Screw	1
26	245977	Yoke Lock Tube	2
27	245980	Pivot Tube	2
28	70272	3/8-16 x 3 1/4 Hex Hd. Cap Screw	2
29	5021	Take Up Collar	1
30	70151	5/16-18 x 1 Hex Hd. Cap Screw	4
31	70701	5/16 Flat Washer ZP	3
32	70646	5/16 Lock Washer ZP	2
33	70549	5/16-18 Hex Nut ZP	4
34	214907	Belt Guard Assembly	1
35	29209	Pulley	1
36	214858	Belt Guard Cover	1
37	70090	1/4-20 x 1/2 Hex Head Cap Screw	5
38	70643	1/4 Lock Washer ZP	5
39	70545	1/4-20 Hex Nut ZP	5
40	5537	Internal Tilt Gear	1
41	245991	Brake Band Assembly	1
42	70242	3/8-16 x 1 1/4 Hex Hd. Cap Screw	6
43	245992	Gear Cover	1
44	70512	3/8-24 x 3/8 Socket Head Set Screw	1
45	5536	Tilt Wheel Assembly	1
46	5535A	Tilt Pinion Shaft	1
47	70982	Roll Pin, 1/4 x 1	1
48	5534	Tilt Pinion	1
49	5533	Tilt Shaft Bearing	1
50	760-40087	Brake Handle Assembly	1
51	233160	Grip	1
52	70969	Cotter Pin, 1/8 x 1 1/2	1
53	70456	3/8-16 x 1 3/4 Carriage Bolt	4
54	760-40032	Skid	2
55	245997	Frame	1
56	1031	Grease Fitting	1
57	217728	Decal, Safety Instructions	1
58	38257	Decal Rotation	1
59	5706	Gilson Name Plate	1
60	70226	3/8-16 x 3/4 Hex Hd. Cap Screw	2
61	1044	Bearing Cup, Drive (inc. with #14)	2
62	1140	Bearing Cone, Drive	2
63	5024P	Take Up Collar, Drive Shaft	1
64	70498	5/16-18 x 5/16 Socket Hd Set Screw	2

ONE-YEAR WARRANTY

This product is warranted to the original purchaser only, to be free of defects in material and workmanship under normal use, for one year from purchase date. Cleform Tool Corp. shall without charge for parts and labor, repair or replace such parts which are found to be defective. All transportation charges for replacement parts must be borne by the purchaser.

For warranty service, the product must be delivered, with proof of purchase date, to the dealer of original purchase, or any factory authorized service dealer. The delivery of the unit must be made no later than 30 days after the expiration of the warranty period.

If difficulty is encountered in having warranty work performed, contact the factory Service Department:

**CLEFORM TOOL CORP.
4343 EASTON ROAD
ST. JOSEPH, MO 64503
800-253-3676 PHONE
888-253-3676 FAX**

Exclusion from this warranty:

1. The following items are not covered under the CLEFORM TOOL CORP. One year Warranty and are warranted by their respective manufacturer.
 - a) Engines, including starters, generators, alternators and gear reducers.
 - b) Enclosed gear transmissions.(Note: A copy of the warranty and service contact information for the above items is furnished with the individual product).
2. All consequential damages, including pickup and delivery of the unit, communication, mileage charges and/or rental of a replacement unit during repairs are not covered under this warranty, nor is any loss of income and/or other loss resulting from the failure of the product to function due to a warranty defect.
3. This warranty will not apply when the product becomes inoperative due to misuse, normal wear, neglect, improper maintenance, accident or freight damage; has not been operated and maintained in accordance with the instructions furnished in the Operator's Manual; or has been altered or modified without approval from the factory Service Department.
4. No parts or products are to be returned to the factory without prior written approval from the factory.

ALL IMPLIED WARRANTIES, INCLUDING THOSE OF MERCHANTABILITY AND FITNESS FOR A PARTICULAR PURPOSE, ARE LIMITED TO ONE YEAR

FROM DATE OF PURCHASE BY THE ORIGINAL RETAIL CUSTOMER AND TO THE EXTENT PERMITTED BY LAW ANY AND ALL IMPLIED WARRANTIES ARE EXCLUDED AND DISCLAIMED AFTER THE EXPIRATION OF SUCH PERIOD.

Some states do not allow limitations on how long an implied warranty lasts, or the exclusion or limitations of incidental or consequential damages, so the above limitations or exclusions may not apply to you.

This warranty gives you specific legal rights, and you may also have other rights, which vary from state to state.

HOW TO OBTAIN PARTS AND SERVICE INFORMATION

For parts and service information, contact either your local dealer or the Cleform Tool Corp. factory:

HOW TO ORDER PARTS

When ordering parts be sure to indicate the following information:

- **Name of each part**
- **Complete part number**
- **Quantity of each part**
- **Model Name** (Include all letters and numbers)
- **Serial Number** (Include all letters and numbers)

